

ESTIMATED SELLABLE 3085 SF (13th FLOOR)
OUTSIDE WALL : 240 SF (ROOF)

(OUTSIDE FACE - EXTERIOR WALL AND
CORRIDOR, CENTERLINE - DEMISING WALL,
INSIDE WALL - SHAFTS)

NOTE: ALL AREAS ARE PRELIMINARY AND SUBJECT TO CHANGE.

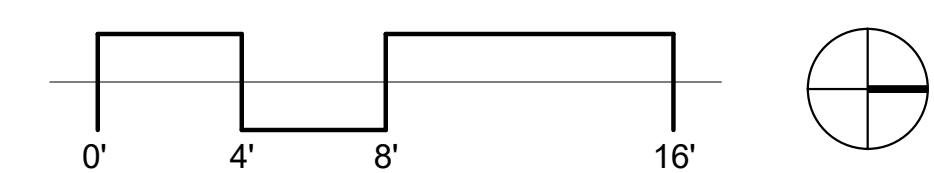

PENTHOUSE TYPE A

3 BR + DEN / 3.5 BATH

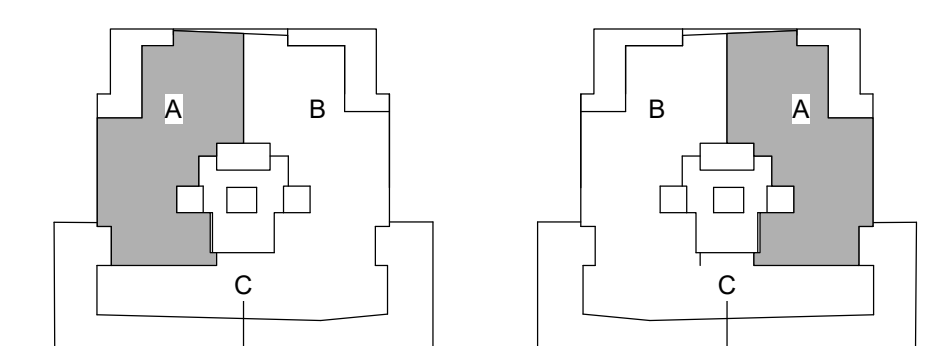
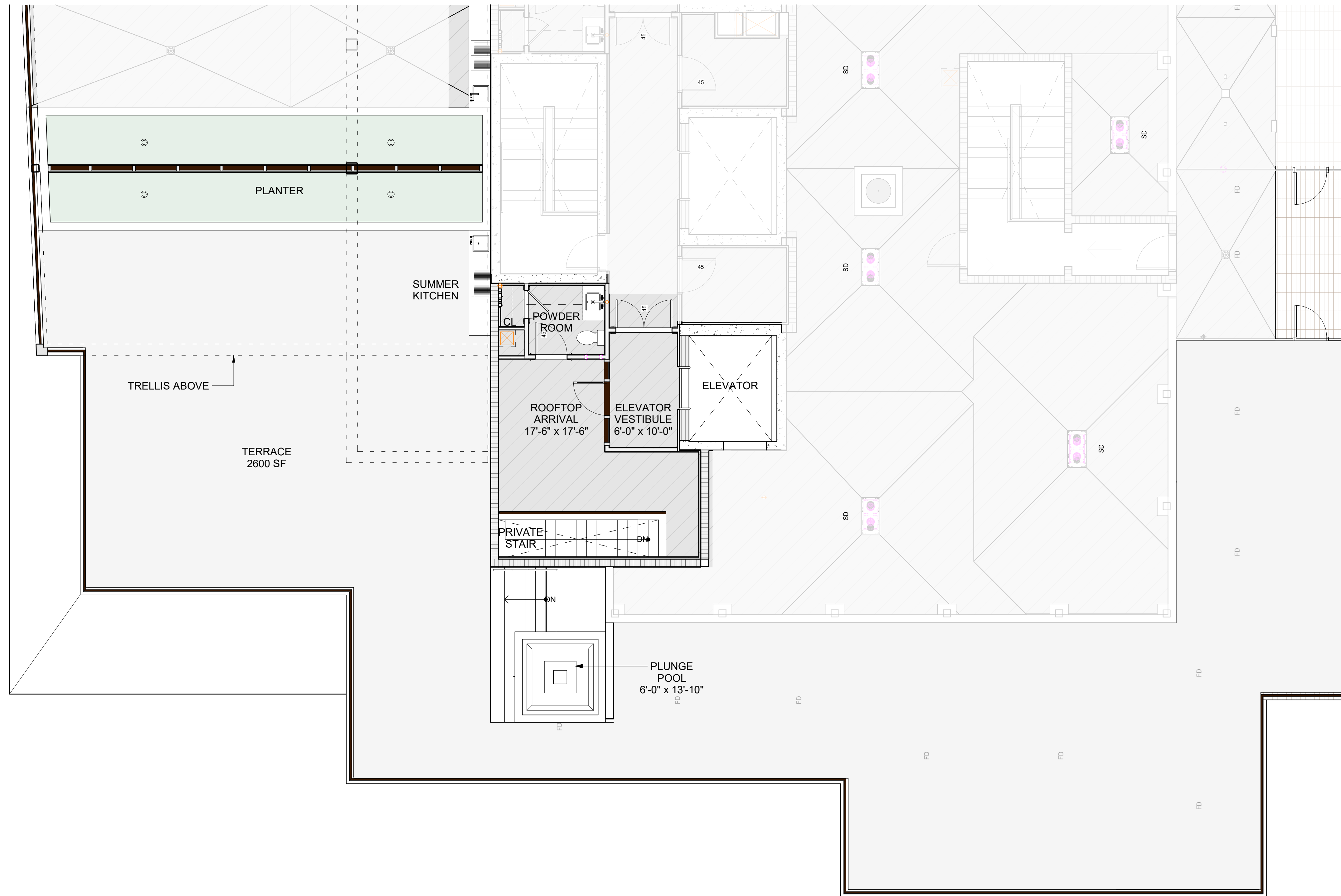

ESTIMATED SELLABLE 240 SF
OUTSIDE WALL : 2332 SF (TERRACE)

(OUTSIDE FACE - EXTERIOR WALL AND
CORRIDOR, CENTERLINE - DEMISING WALL,
INSIDE WALL - SHAFTS)

NOTE: ALL AREAS ARE PRELIMINARY AND SUBJECT TO CHANGE.

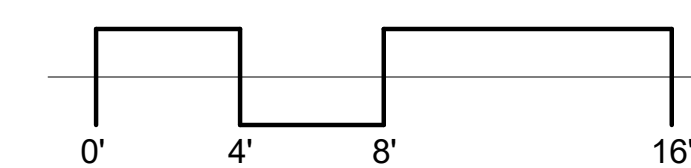

PENTHOUSE TYPE A - ROOF TERRACE

3 BR + DEN / 3.5 BATH

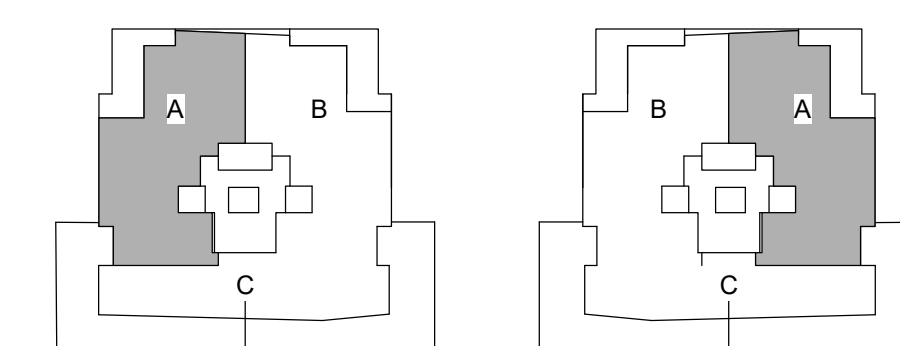
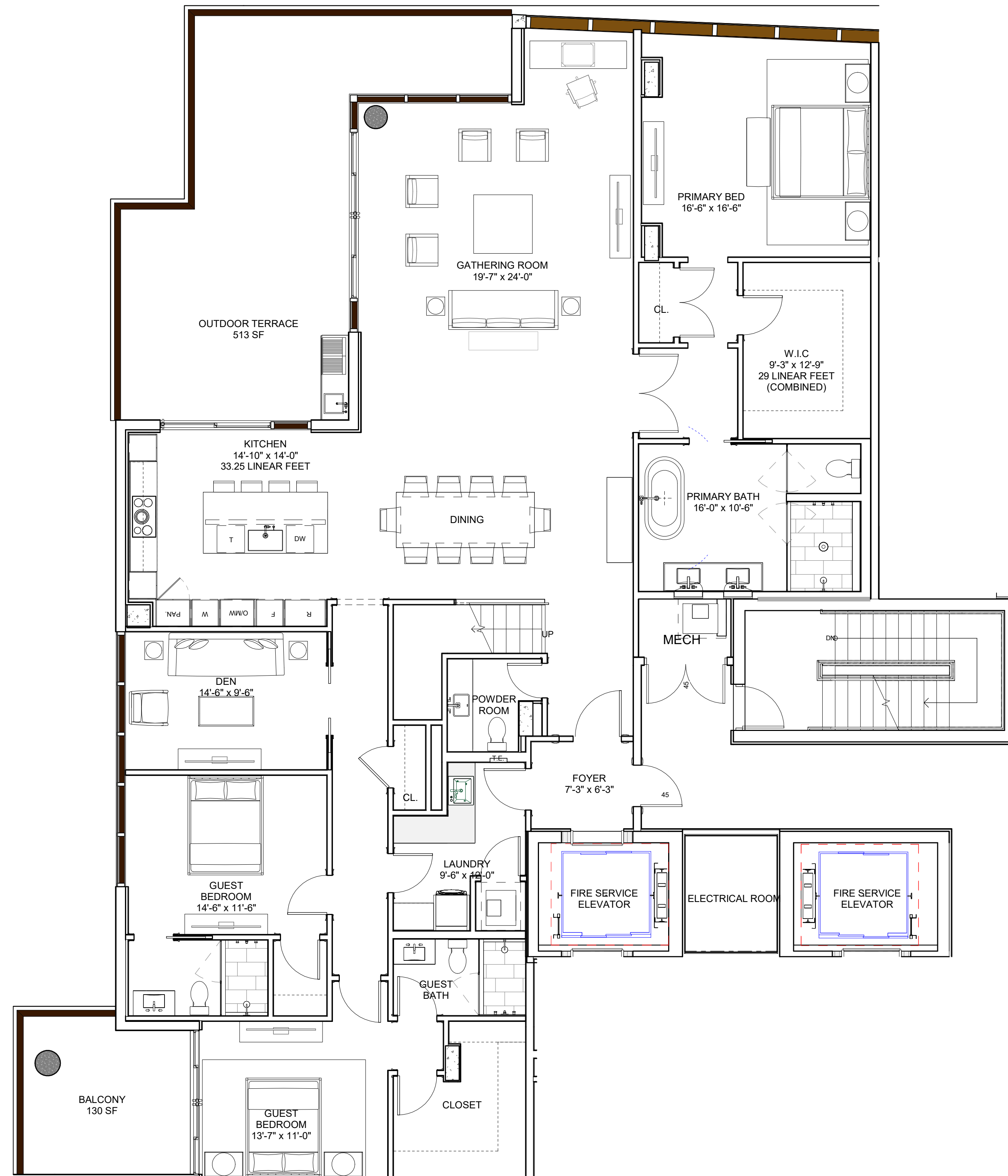

ESTIMATED SELLABLE 3085 SF (13th FLOOR)
OUTSIDE WALL : 240 SF (ROOF)

(OUTSIDE FACE - EXTERIOR WALL AND CORRIDOR, CENTERLINE - DEMISING WALL, INSIDE WALL - SHAFTS)

NOTE: ALL AREAS ARE PRELIMINARY AND SUBJECT TO CHANGE.

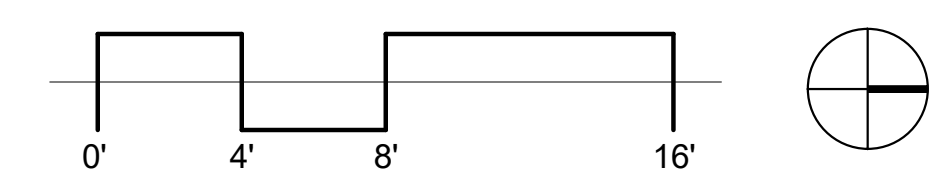

PENTHOUSE TYPE A

3 BR + DEN / 3.5 BATH

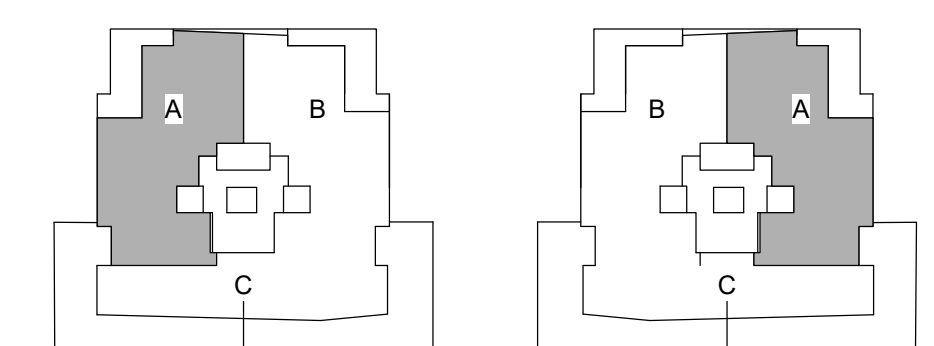
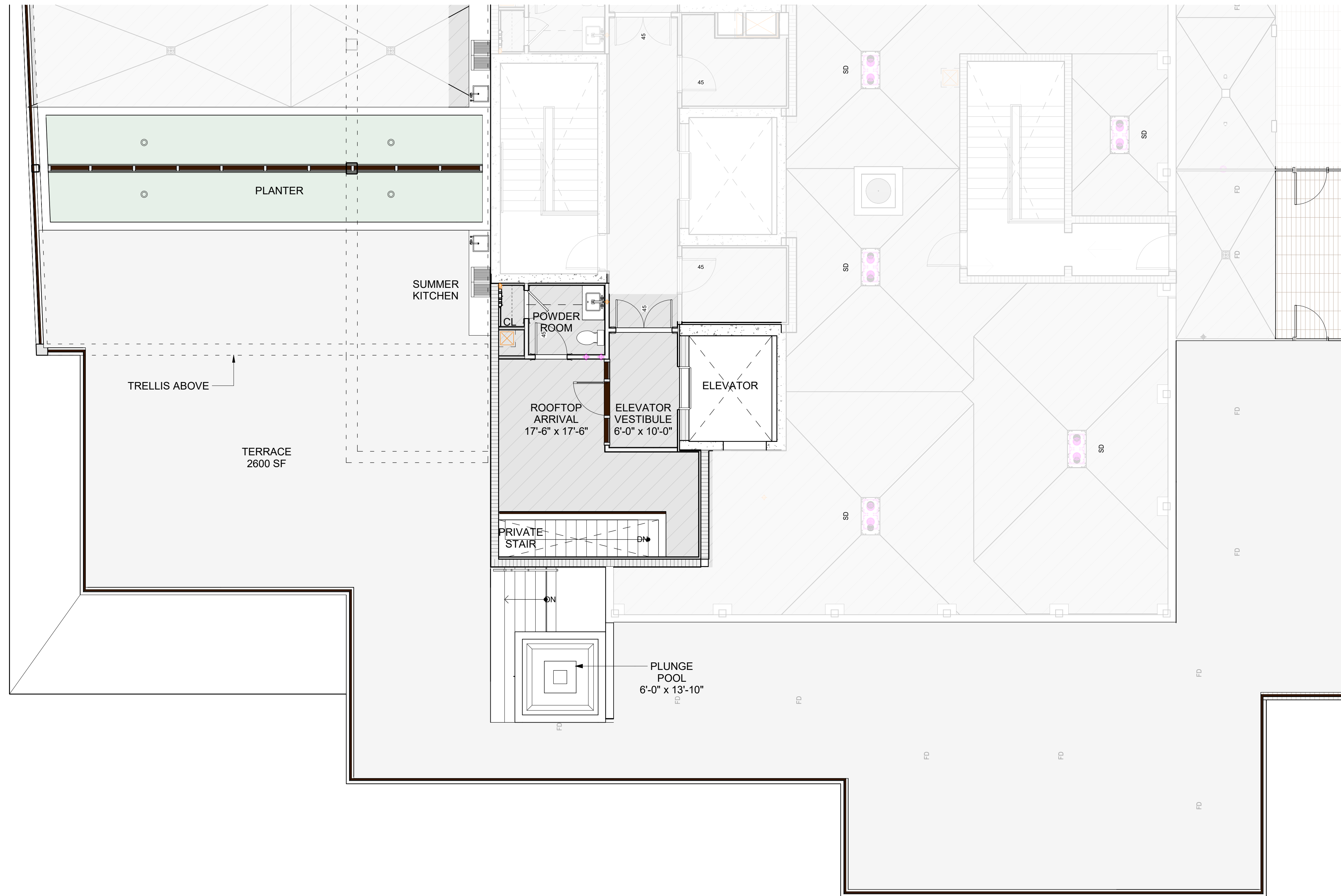

ESTIMATED SELLABLE 240 SF
OUTSIDE WALL : 2332 SF (TERRACE)

(OUTSIDE FACE - EXTERIOR WALL AND
CORRIDOR, CENTERLINE - DEMISING WALL,
INSIDE WALL - SHAFTS)

NOTE: ALL AREAS ARE PRELIMINARY AND SUBJECT TO CHANGE.

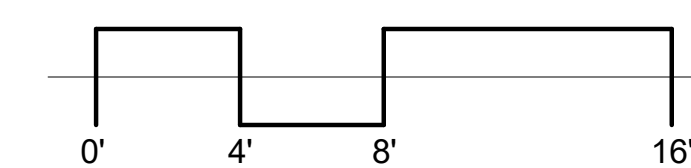

PENTHOUSE TYPE A - ROOF TERRACE

3 BR + DEN / 3.5 BATH

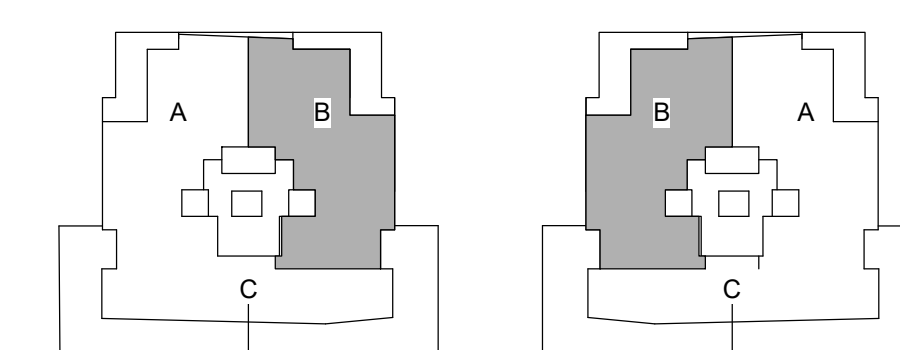
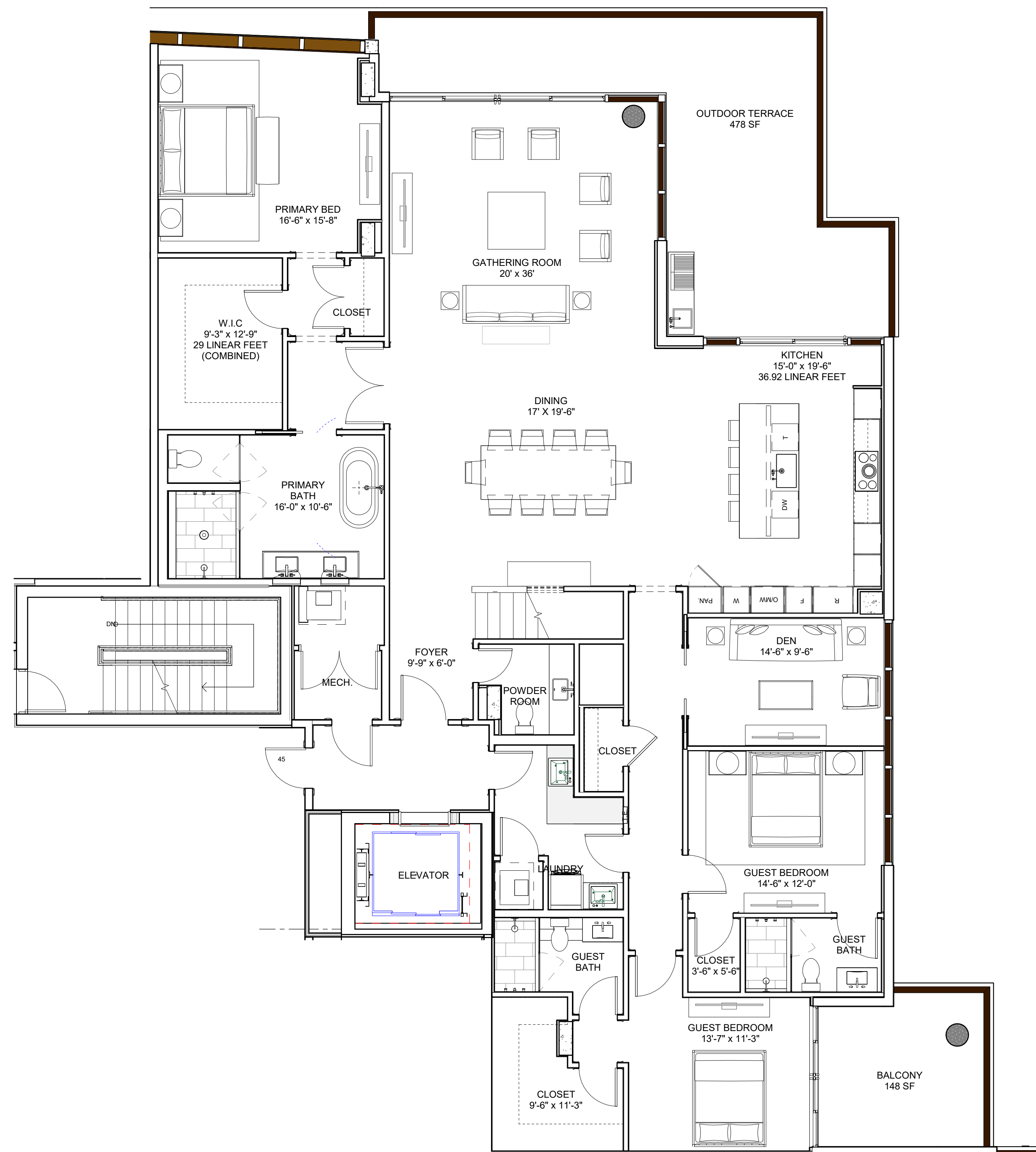

ESTIMATED SELLABLE 3200 SF (13th FLOOR)
OUTSIDE WALL : 280 SF (ROOF)

(OUTSIDE FACE - EXTERIOR WALL AND CORRIDOR, CENTERLINE - DEMISING WALL, INSIDE WALL - SHAFTS)

NOTE: ALL AREAS ARE PRELIMINARY AND SUBJECT TO CHANGE.

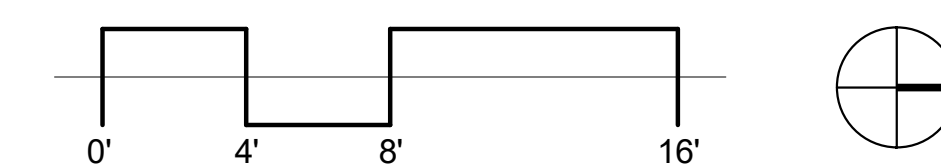

PENTHOUSE TYPE B

3 BR + DEN / 3.5 BATH

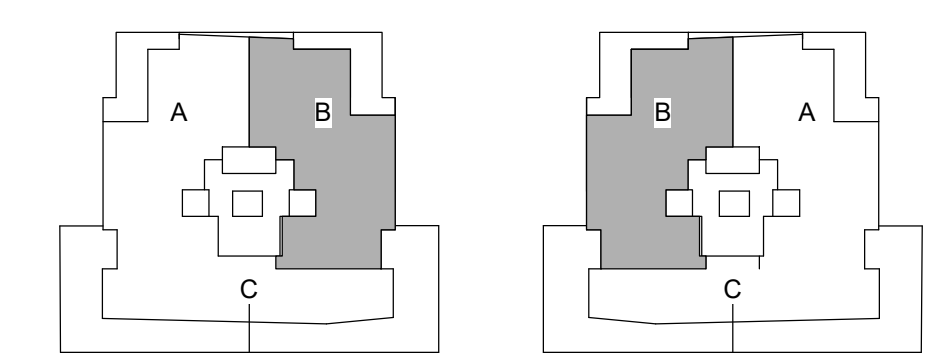
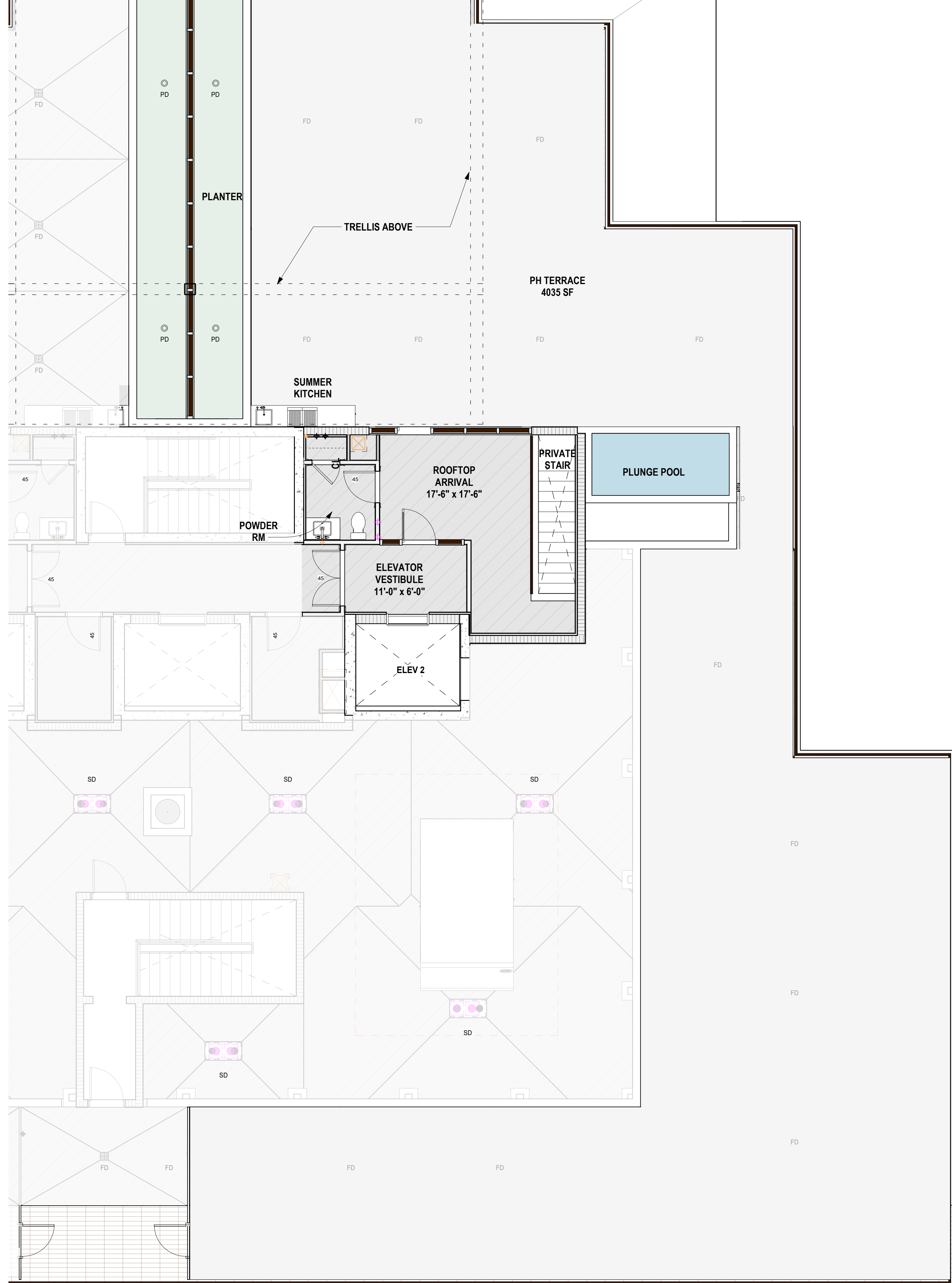

ESTIMATED SELLABLE 284 SF
OUTSIDE WALL : 2729 SF (TERRACE)

(OUTSIDE FACE - EXTERIOR WALL AND
CORRIDOR, CENTERLINE - DEMISING WALL,
INSIDE WALL - SHAFTS)

NOTE: ALL AREAS ARE PRELIMINARY AND SUBJECT TO CHANGE.

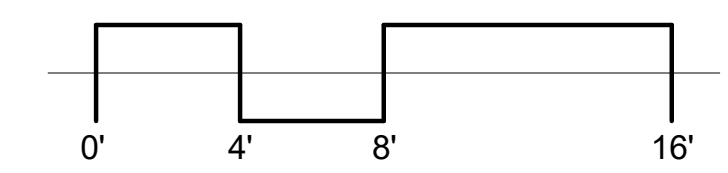

PENTHOUSE TYPE B - ROOF TERRACE

3 BR + DEN / 3.5 BATH

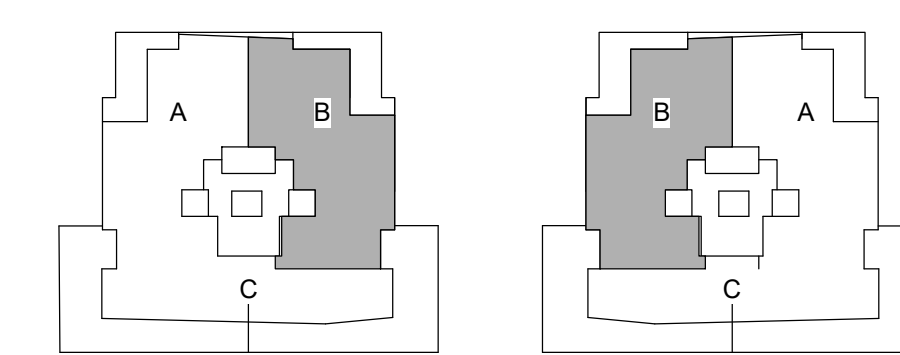
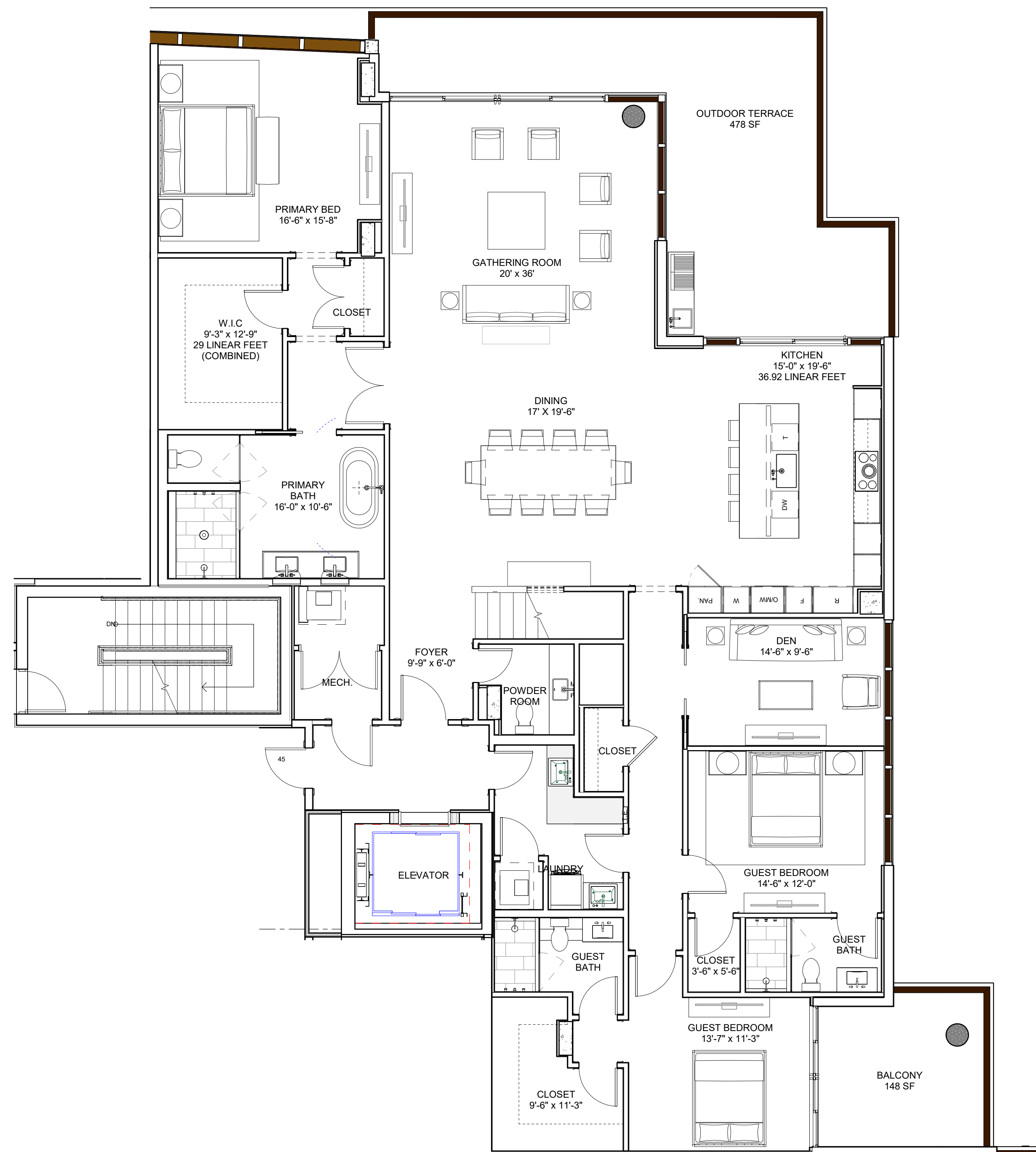

ESTIMATED SELLABLE 3200 SF (13th FLOOR)
OUTSIDE WALL : 280 SF (ROOF)

(OUTSIDE FACE - EXTERIOR WALL AND CORRIDOR, CENTERLINE - DEMISING WALL, INSIDE WALL - SHAFTS)

NOTE: ALL AREAS ARE PRELIMINARY AND SUBJECT TO CHANGE.

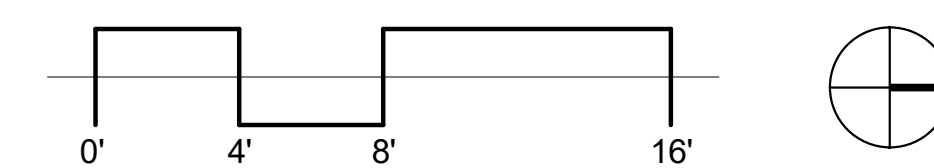

PENTHOUSE TYPE B

3 BR + DEN / 3.5 BATH

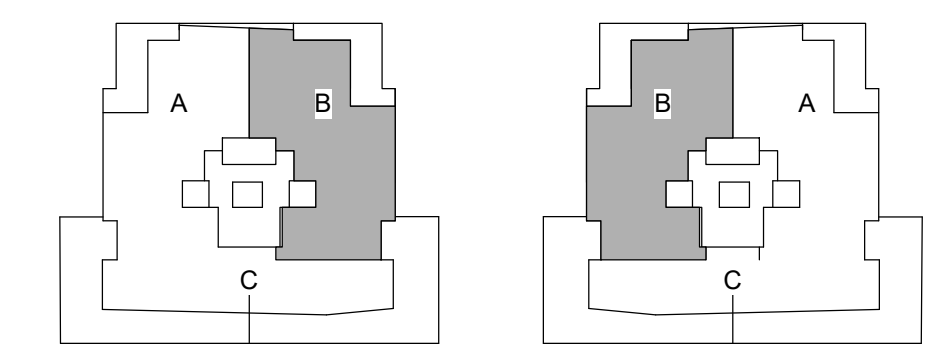
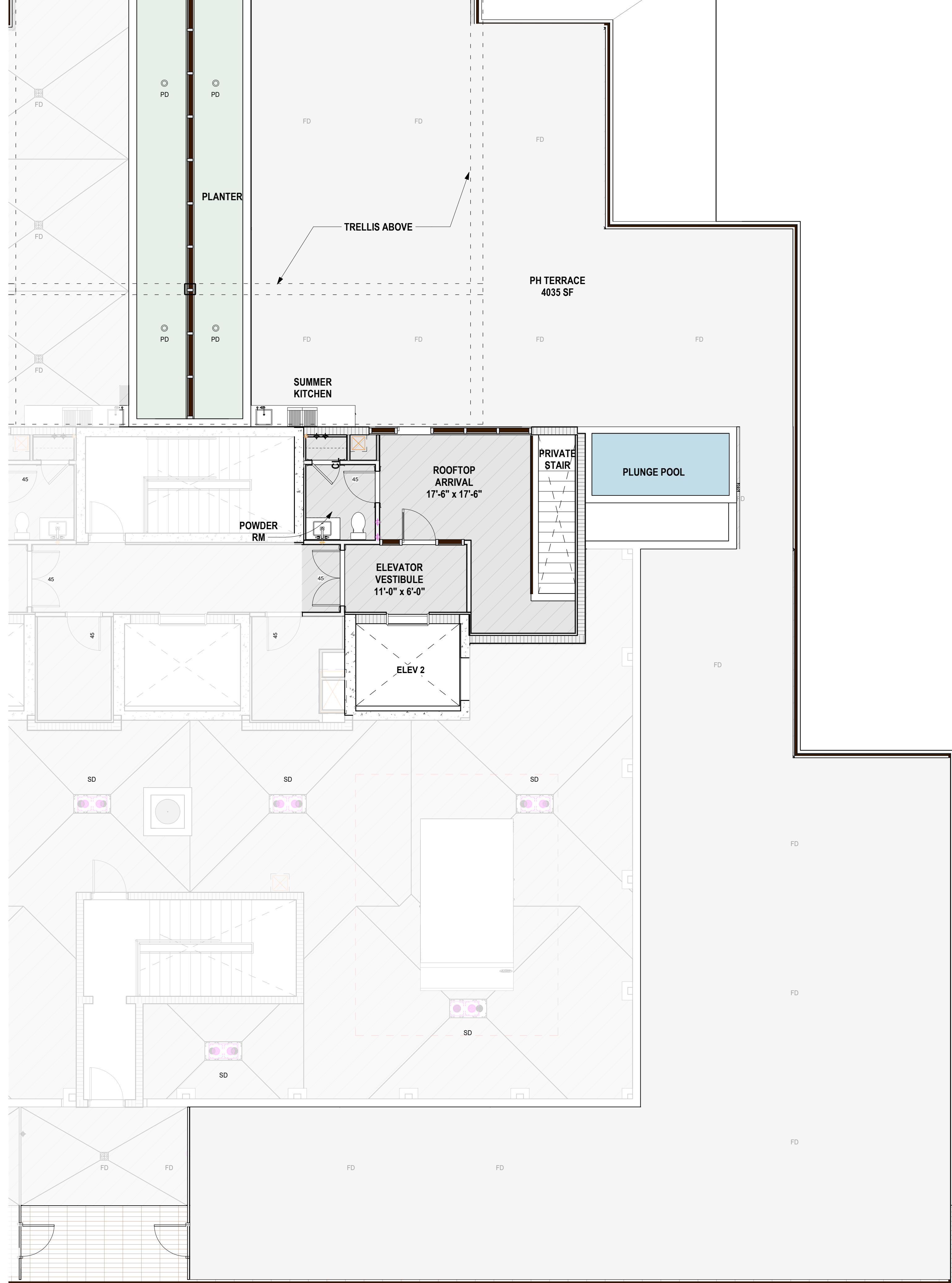

ESTIMATED SELLABLE 284 SF
OUTSIDE WALL : 2729 SF (TERRACE)

(OUTSIDE FACE - EXTERIOR WALL AND
CORRIDOR, CENTERLINE - DEMISING WALL,
INSIDE WALL - SHAFTS)

NOTE: ALL AREAS ARE PRELIMINARY AND SUBJECT TO CHANGE.

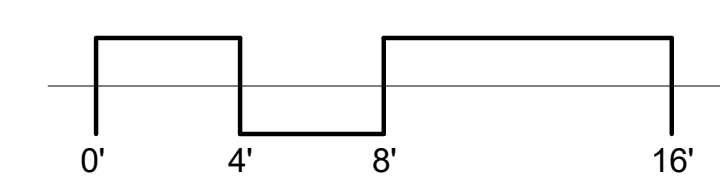

PENTHOUSE TYPE B - ROOF TERRACE
3 BR + DEN / 3.5 BATH

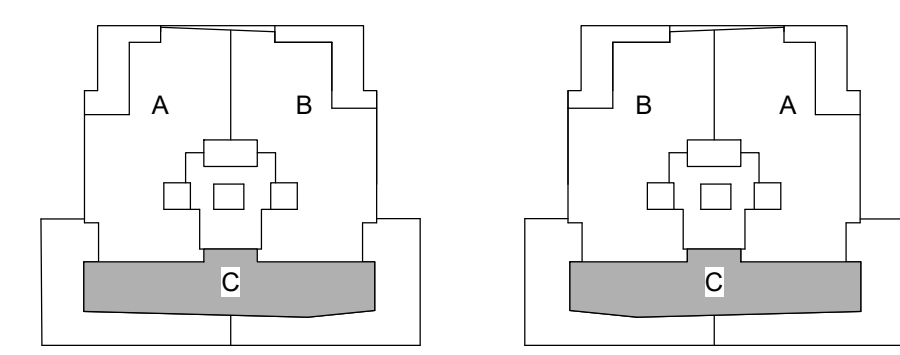
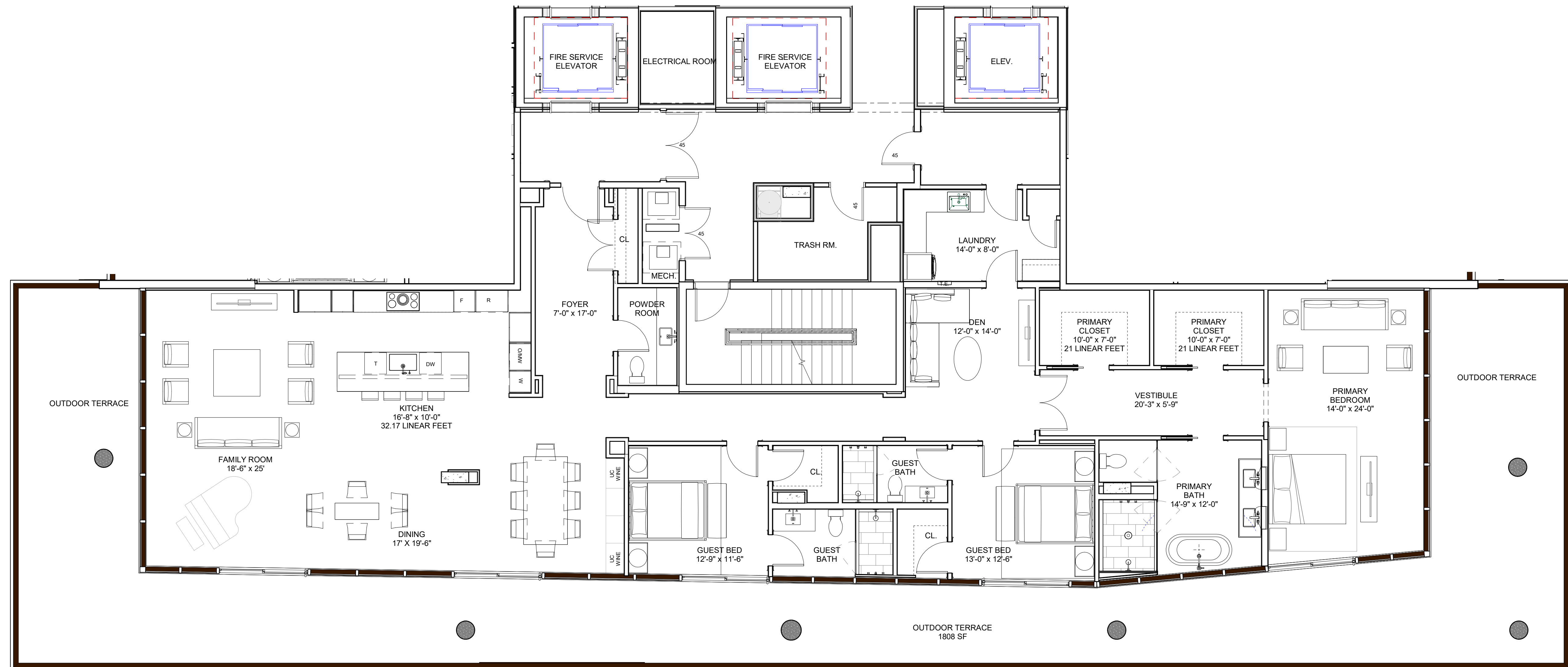

**ESTIMATED SELLABLE
OUTSIDE WALL : 3238 SF**

(OUTSIDE FACE - EXTERIOR WALL AND
CORRIDOR, CENTERLINE - DEMISING WALL,
INSIDE WALL - SHAFTS)

NOTE: ALL AREAS ARE PRELIMINARY AND SUBJECT TO CHANGE.

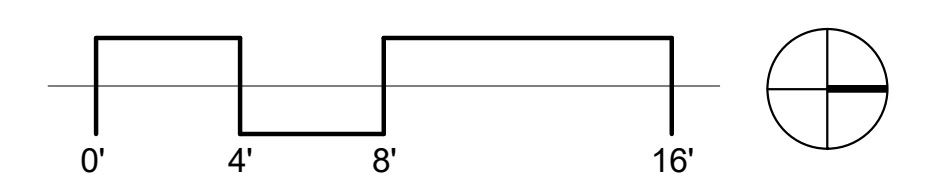

PENTHOUSE TYPE C
3 BR + DEN / 3.5 BATH

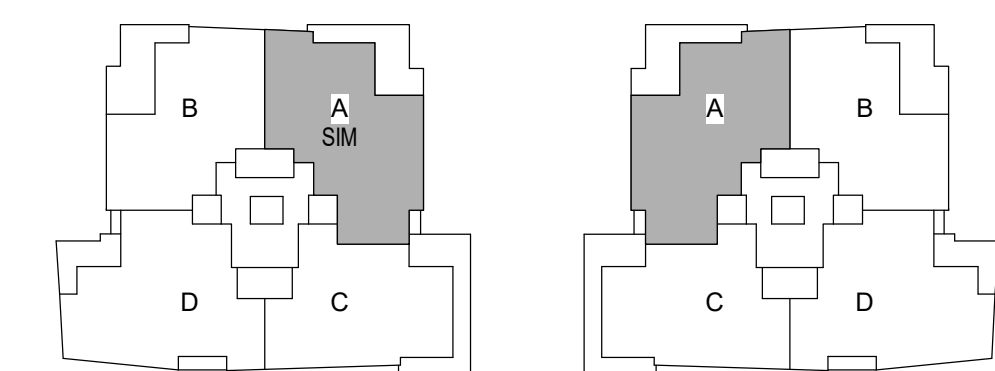
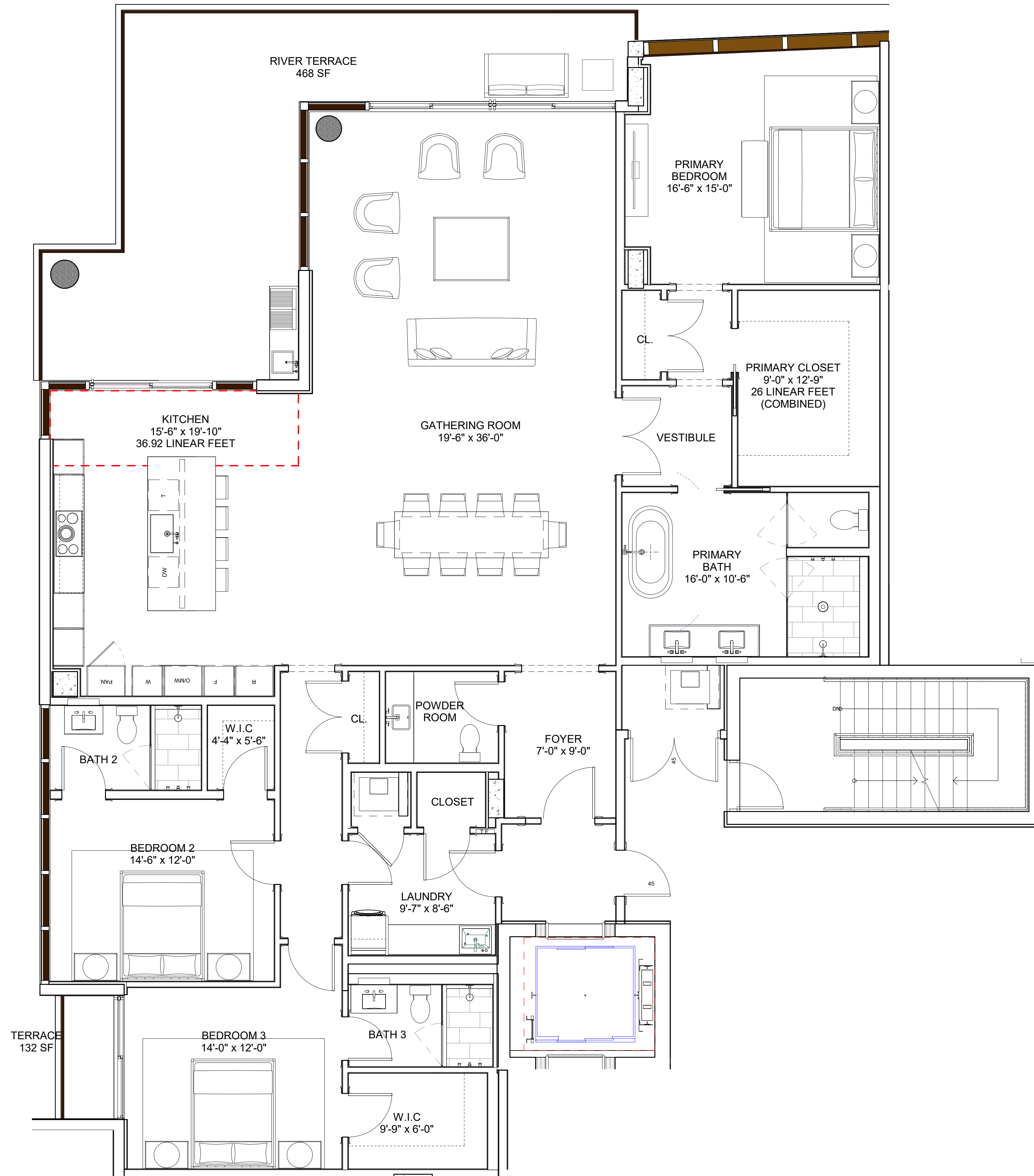

TYPICAL FLOORS 5-7-9-11

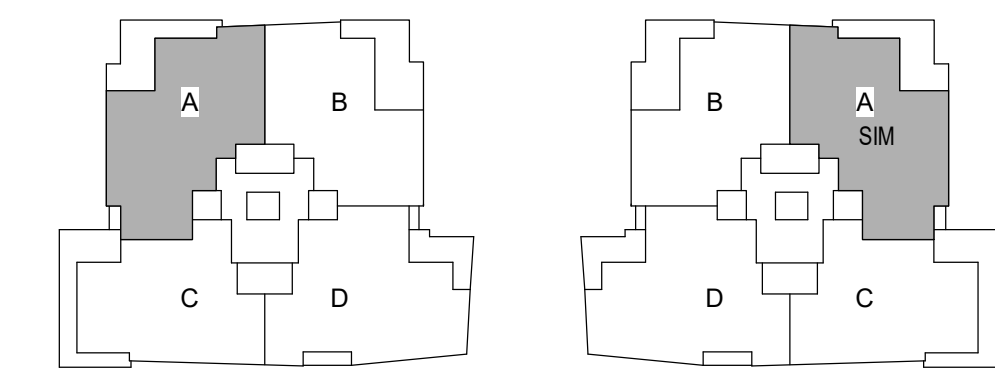

TYPICAL FLOORS 6-8-10-12

**ESTIMATED SELLABLE
OUTSIDE WALL : 2860 SF**

BOMA GROSS: (OUTSIDE FACE - EXTERIOR
WALL AND CORRIDOR, CENTERLINE - DEMISING
WALL, INSIDE WALL - SHAFTS)

NOTE: ALL AREAS ARE PRELIMINARY AND SUBJECT TO CHANGE.

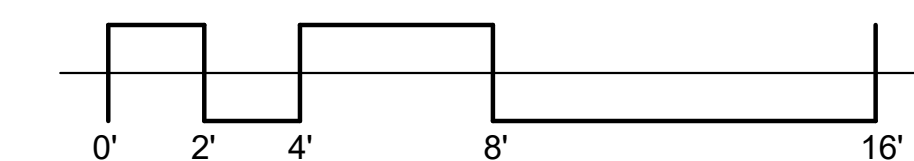

UNIT TYPE A
3 BR / 3.5 BATH

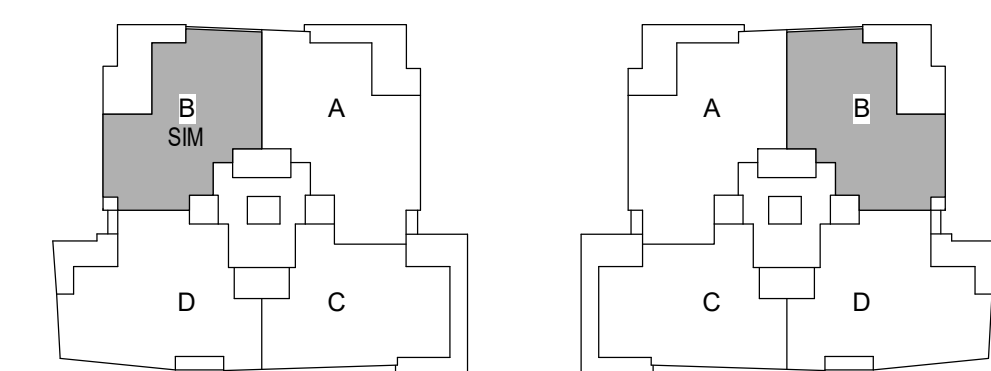
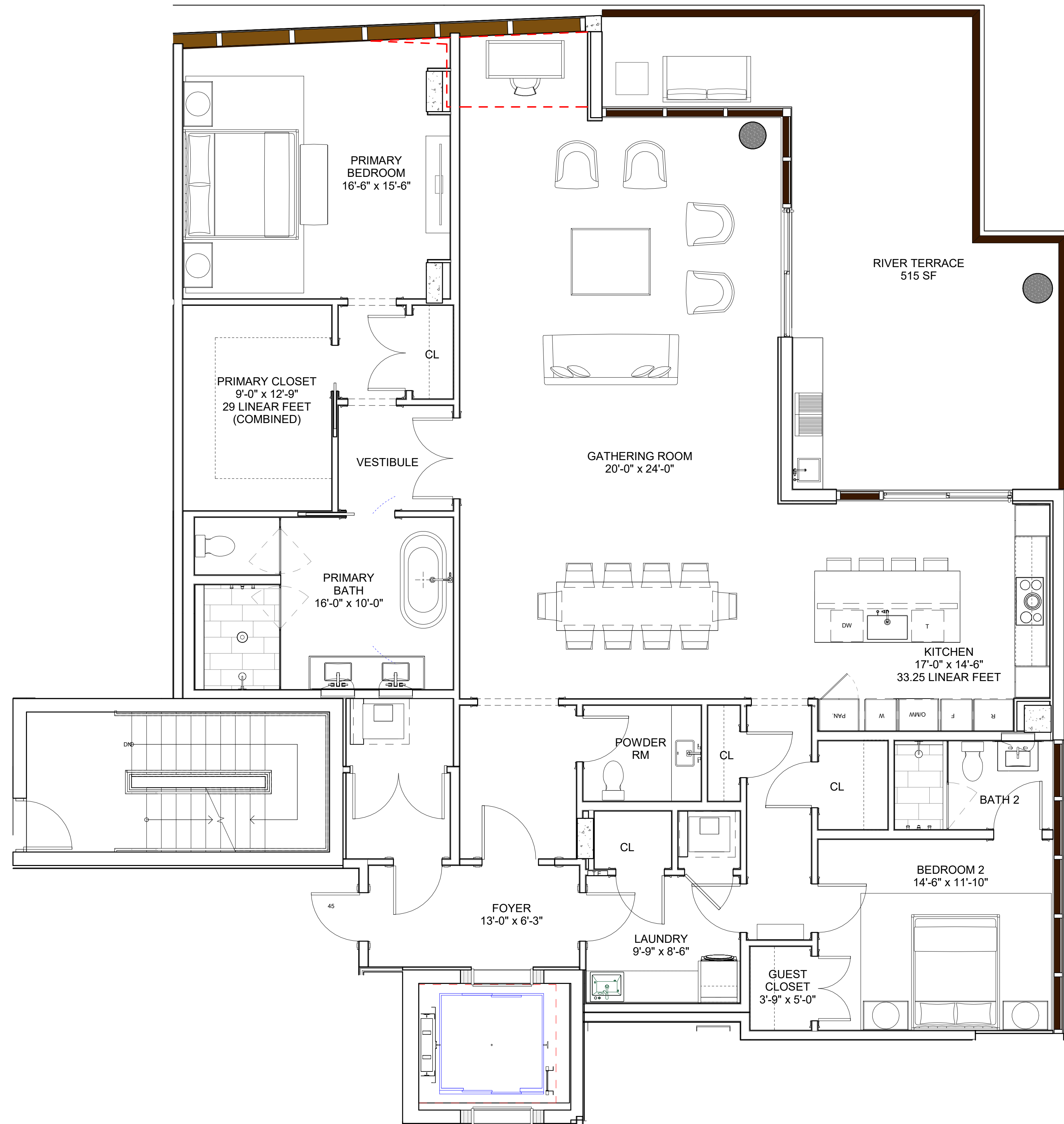

TYPICAL FLOORS 5-7-9-11

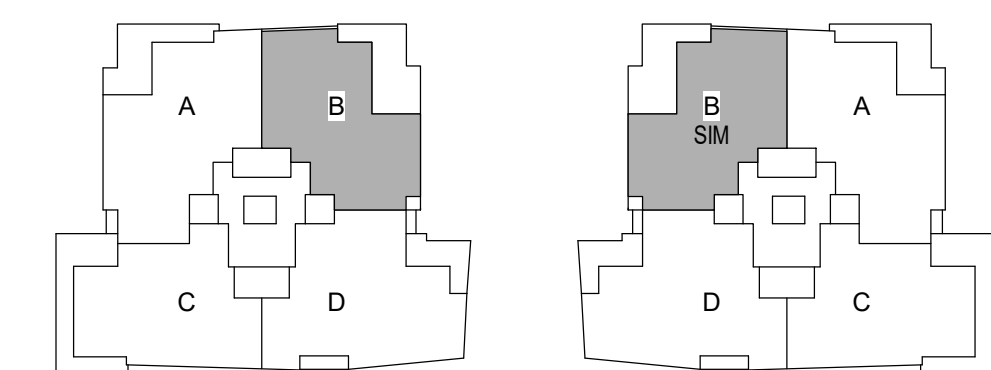

TYPICAL FLOORS 6-8-10-12

**ESTIMATED SELLABLE
OUTSIDE WALL : 2600 SF**

BOMA GROSS: (OUTSIDE FACE - EXTERIOR
WALL AND CORRIDOR, CENTERLINE - DEMISING
WALL, INSIDE WALL - SHAFTS)

NOTE: ALL AREAS ARE PRELIMINARY AND SUBJECT TO CHANGE.

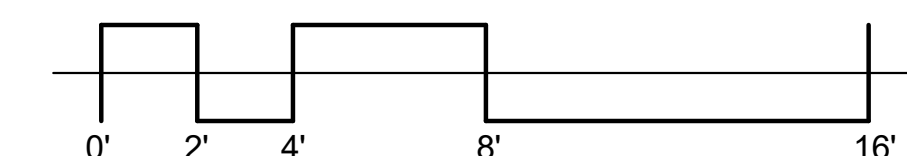

UNIT TYPE B
2 BR / 2.5 BATH

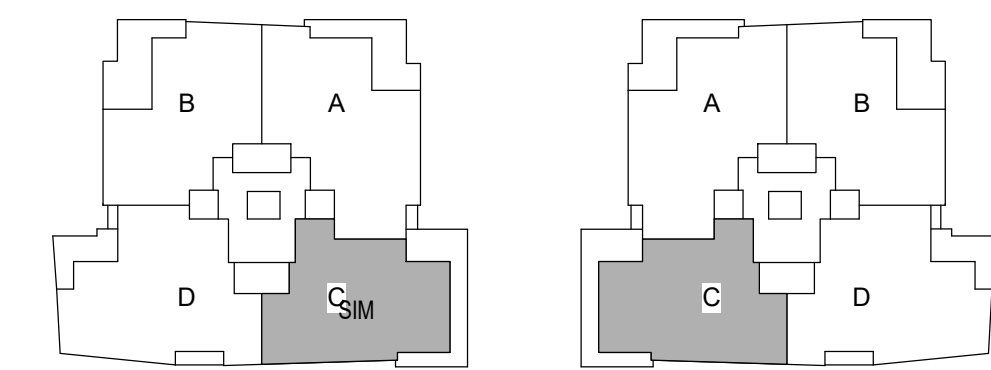
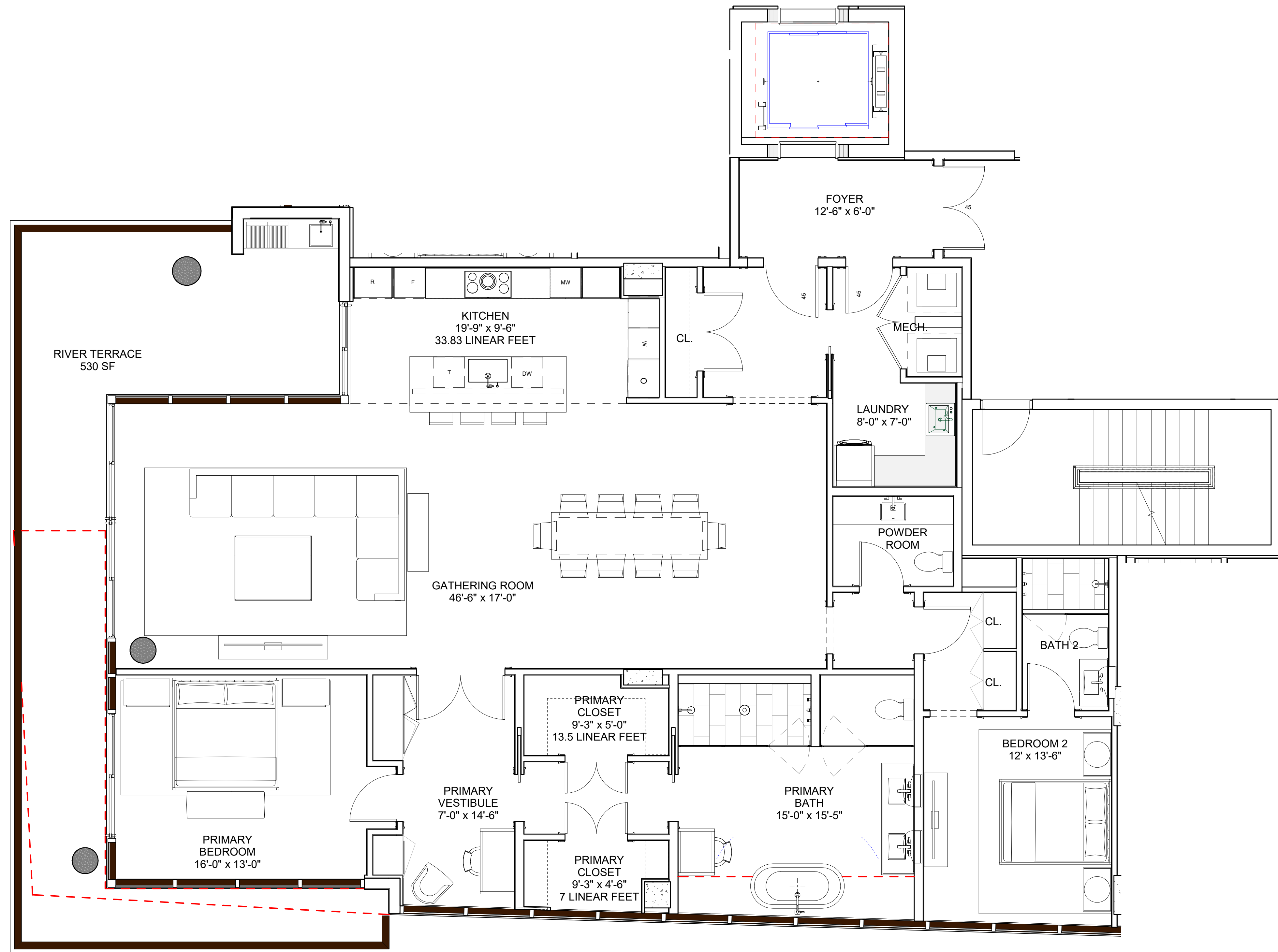

TYPICAL FLOORS 5-7-9-11

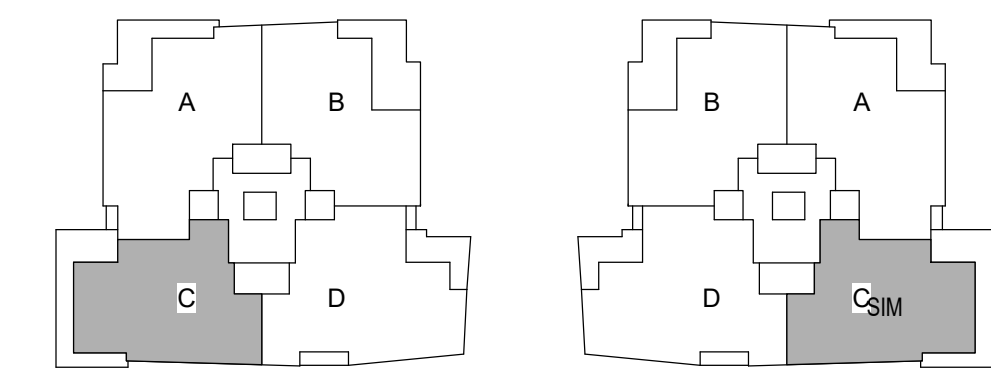

TYPICAL FLOORS 6-8-10-12

**ESTIMATED SELLABLE
OUTSIDE WALL : 2400 SF**

BOMA GROSS: (OUTSIDE FACE - EXTERIOR
WALL AND CORRIDOR, CENTERLINE - DEMISING
WALL, INSIDE WALL - SHAFTS)

NOTE: ALL AREAS ARE PRELIMINARY AND SUBJECT TO CHANGE.

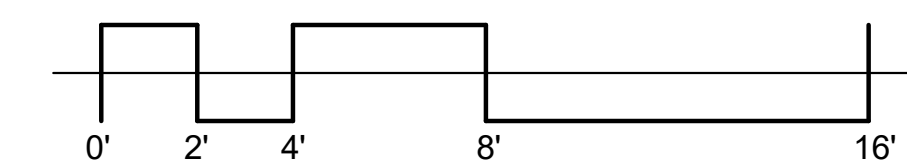

UNIT TYPE C
2 BR / 2.5 BATH

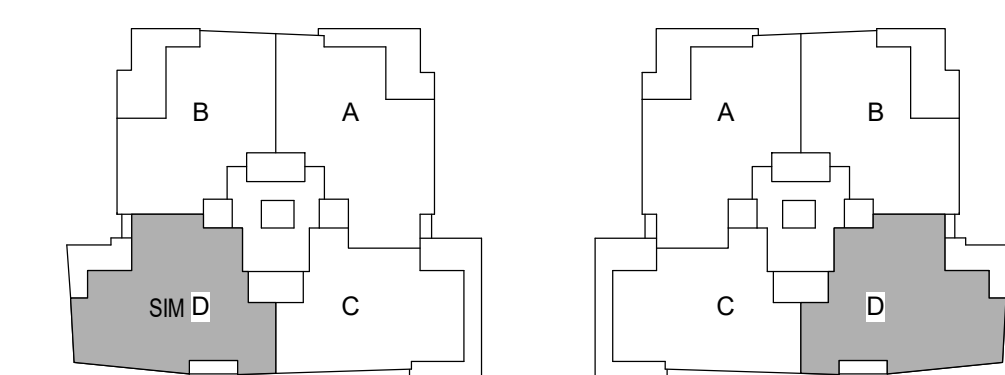
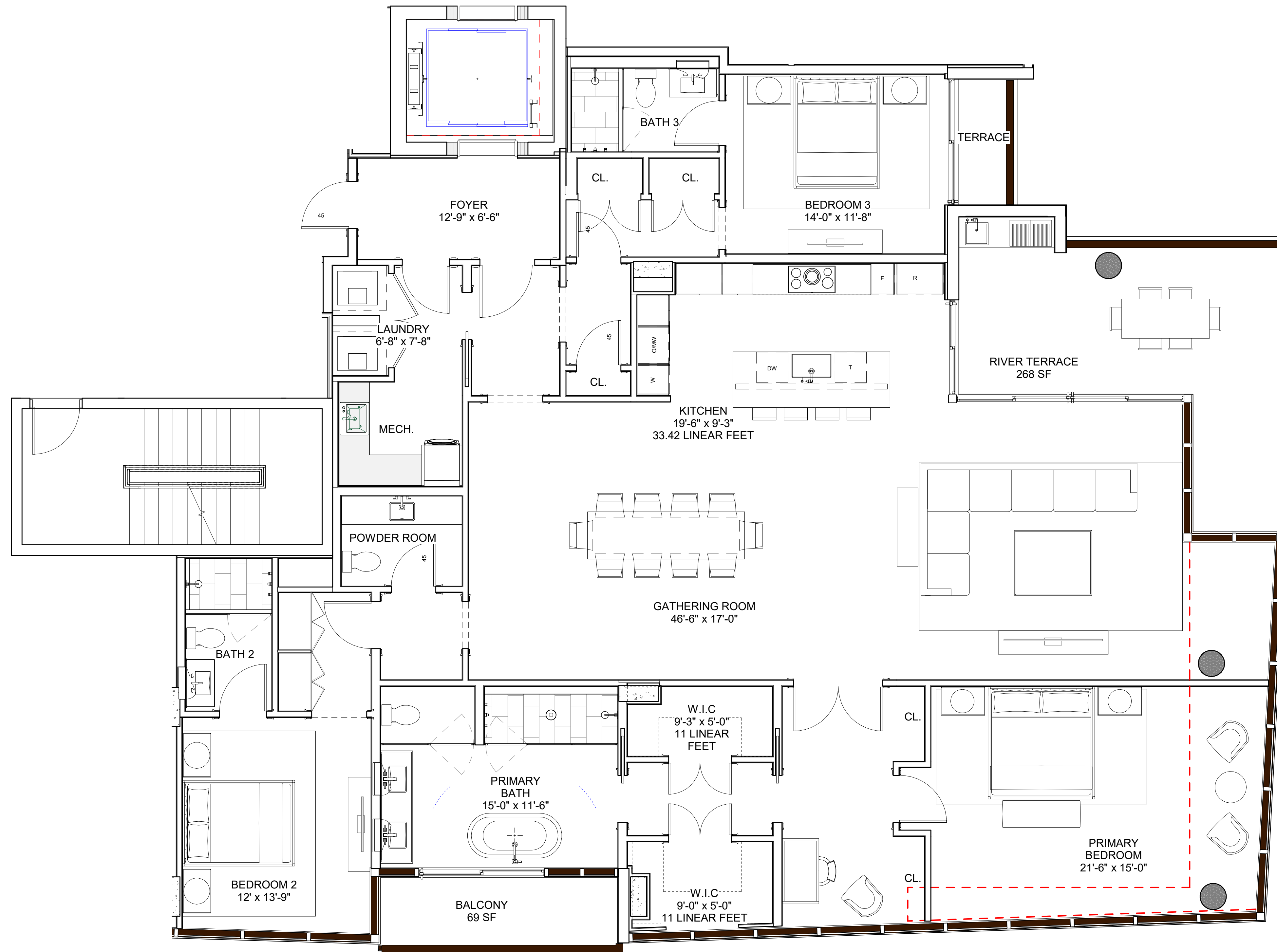

TYPICAL FLOORS 5-7-9-11

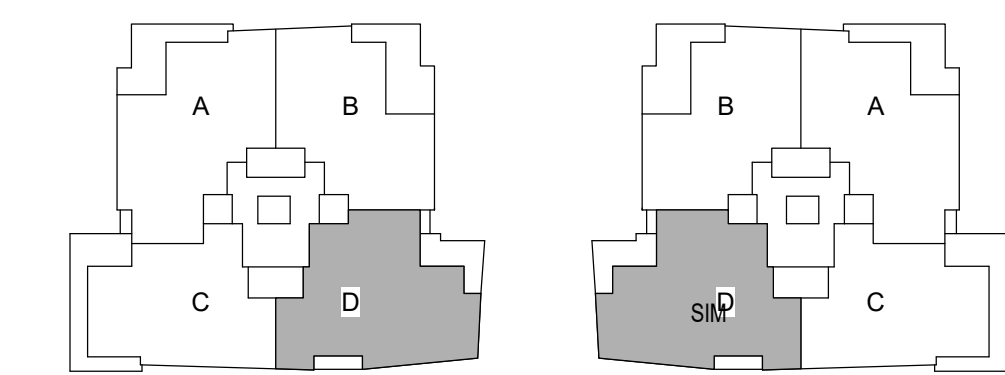

TYPICAL FLOORS 6-8-10-12

**ESTIMATED SELLABLE
OUTSIDE WALL : 2940 SF**

BOMA GROSS: (OUTSIDE FACE - EXTERIOR
WALL AND CORRIDOR, CENTERLINE - DEMISING
WALL, INSIDE WALL - SHAFTS)

NOTE: ALL AREAS ARE PRELIMINARY AND SUBJECT TO CHANGE.

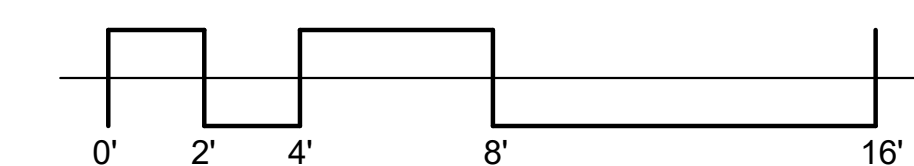

UNIT TYPE D
3 BR / 3.5 BATH

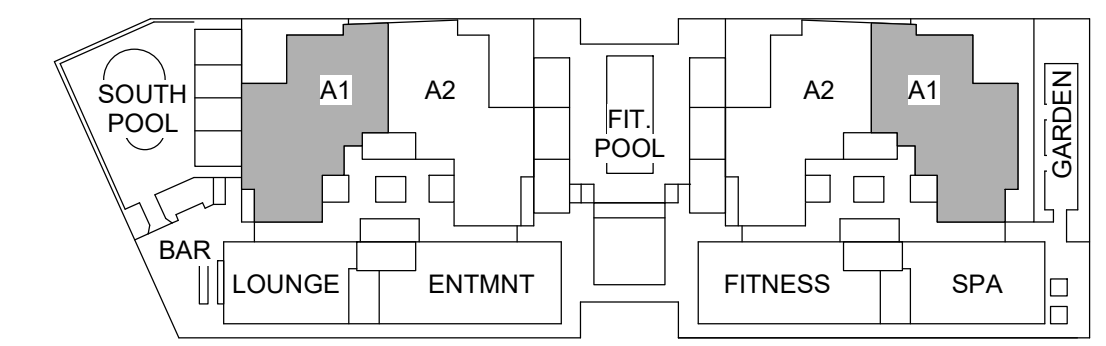
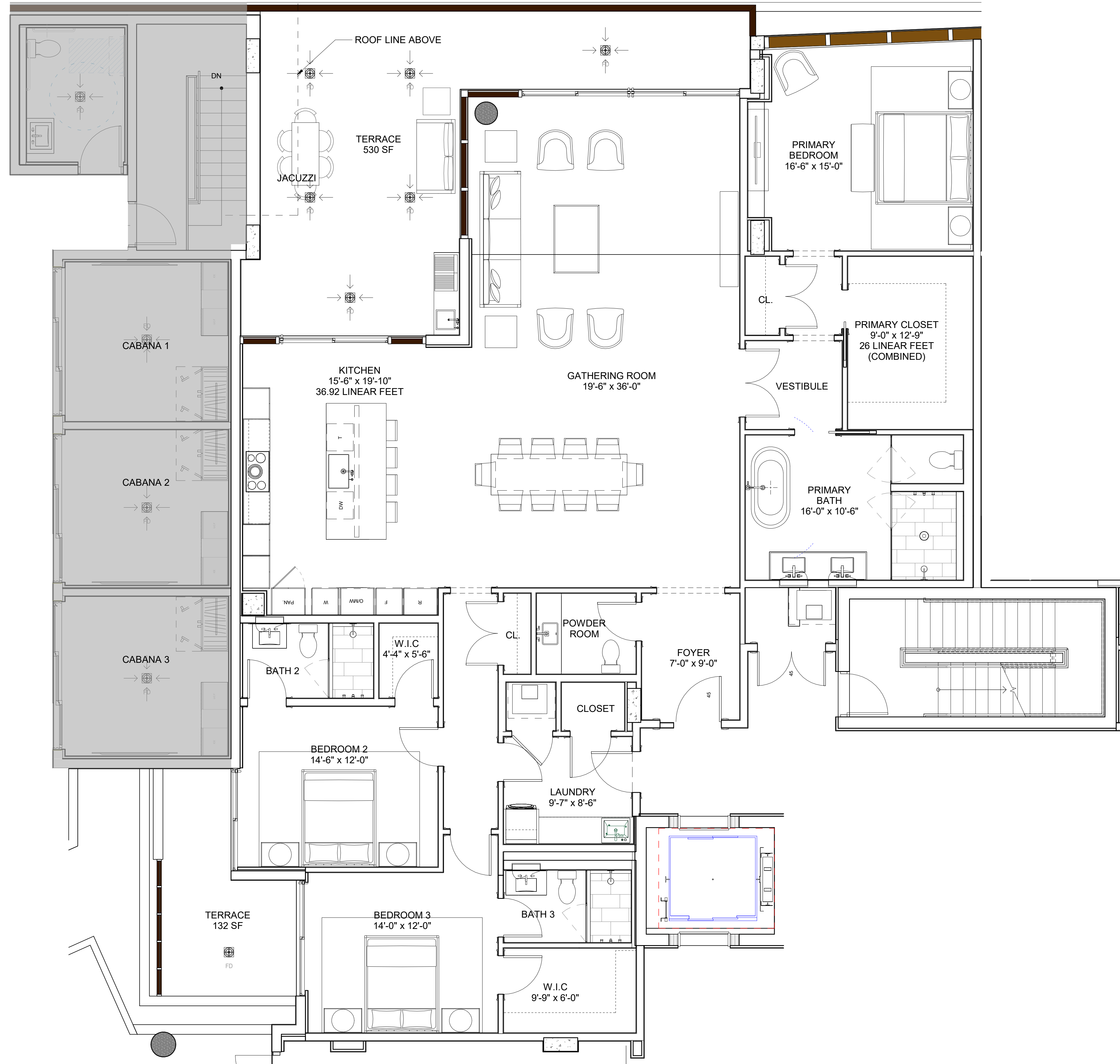

**ESTIMATED SELLABLE
OUTSIDE WALL : 2860 SF**

BOMA GROSS: (OUTSIDE FACE - EXTERIOR
WALL AND CORRIDOR, CENTERLINE - DEMISING
WALL, INSIDE WALL - SHAFTS)

2750 SF

NOTE: ALL AREAS ARE PRELIMINARY AND SUBJECT TO CHANGE.

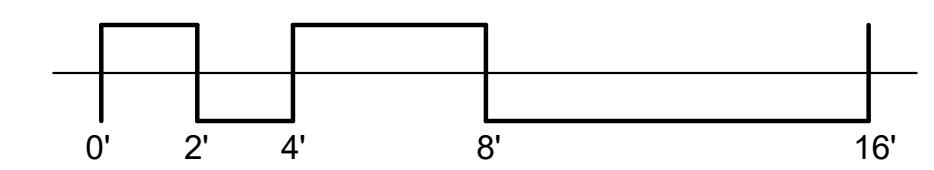

VILLA TYPE A1
3 BR / 3.5 BATH

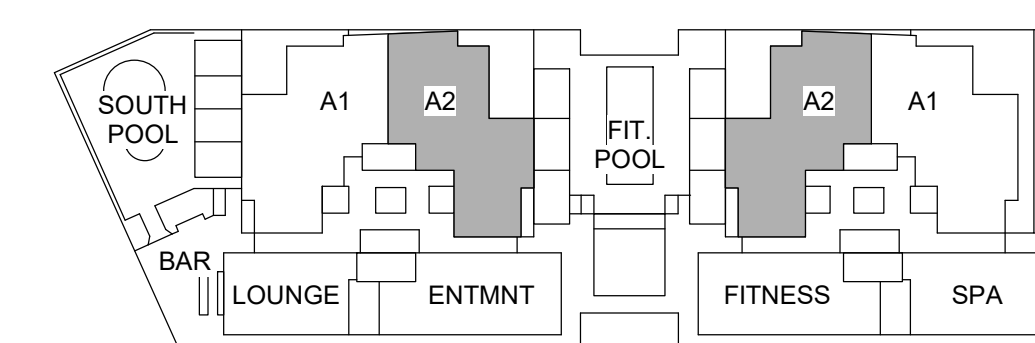
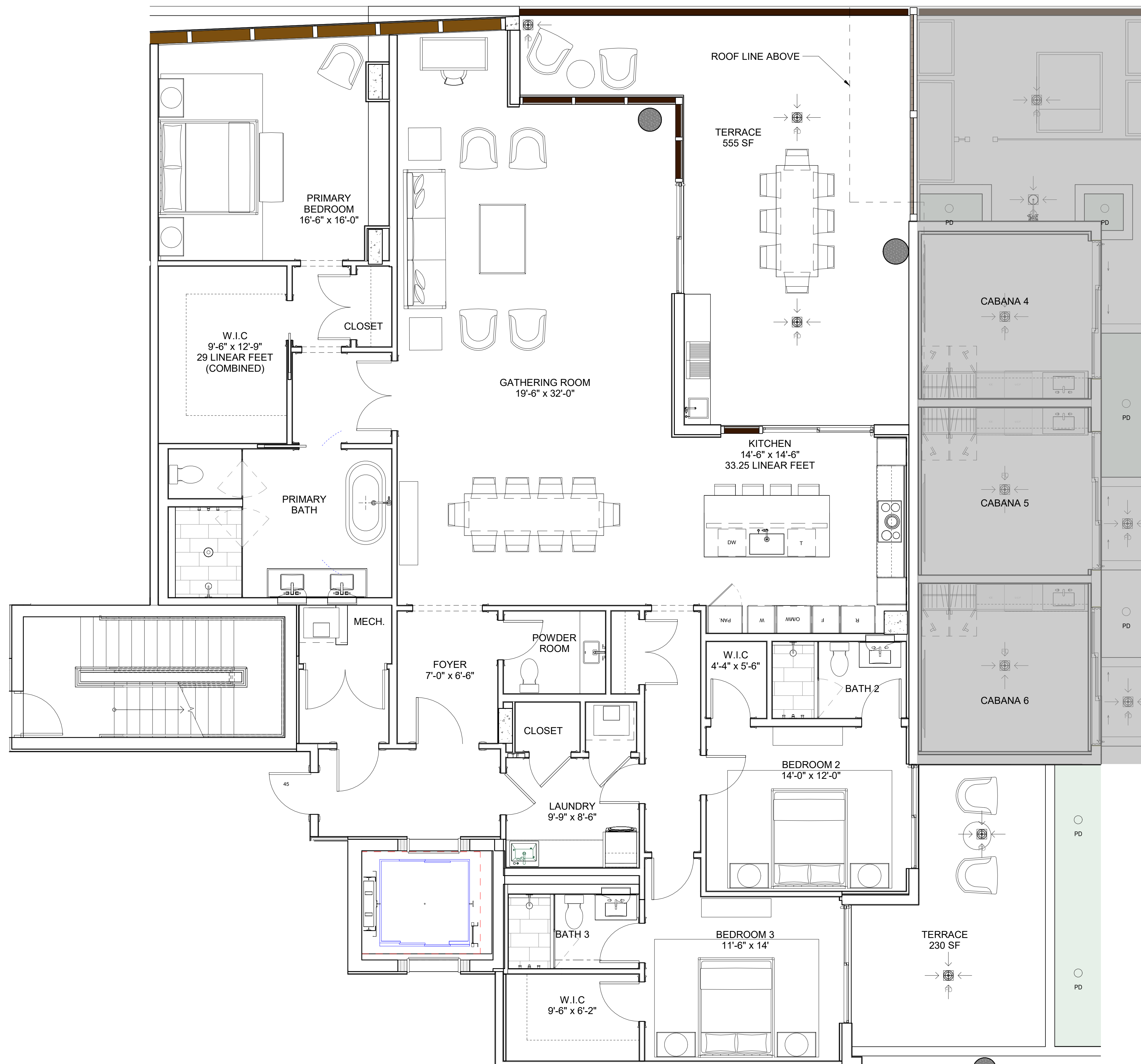

**ESTIMATED SELLABLE
OUTSIDE WALL : 2900 SF**

BOMA GROSS: (OUTSIDE FACE - EXTERIOR
WALL AND CORRIDOR, CENTERLINE - DEMISING
WALL, INSIDE WALL - SHAFTS)

2790 SF

NOTE: ALL AREAS ARE PRELIMINARY AND SUBJECT TO CHANGE.

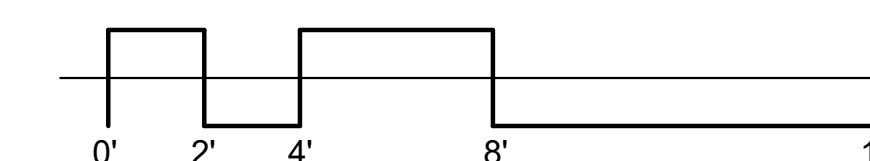

VILLA TYPE A2

3 BR / 3.5 BATH

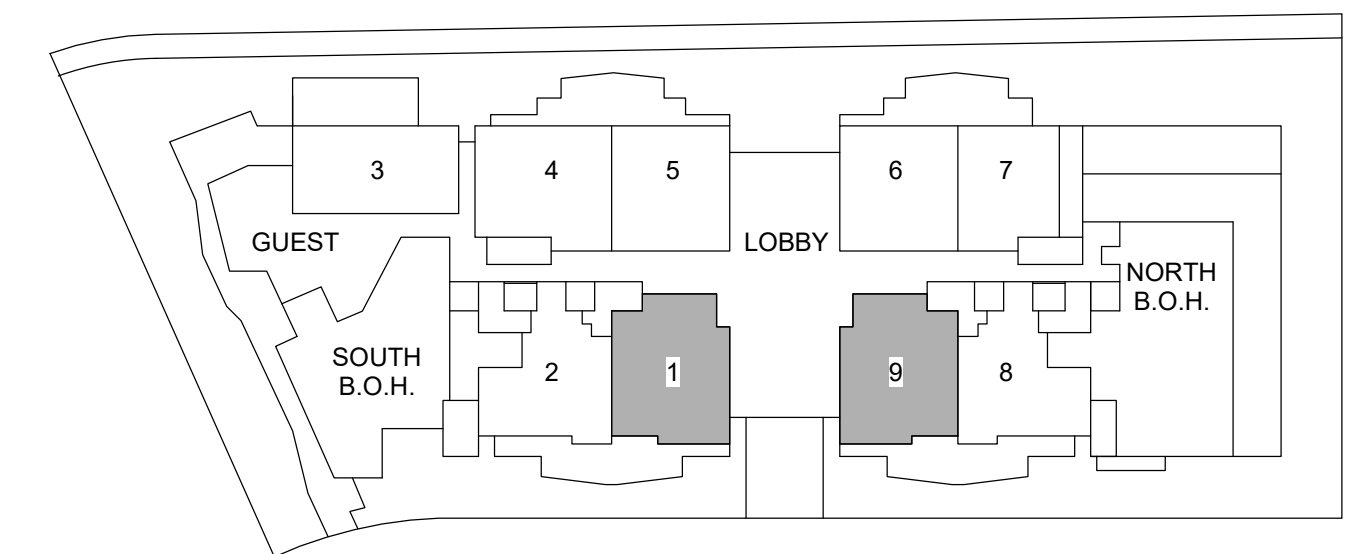
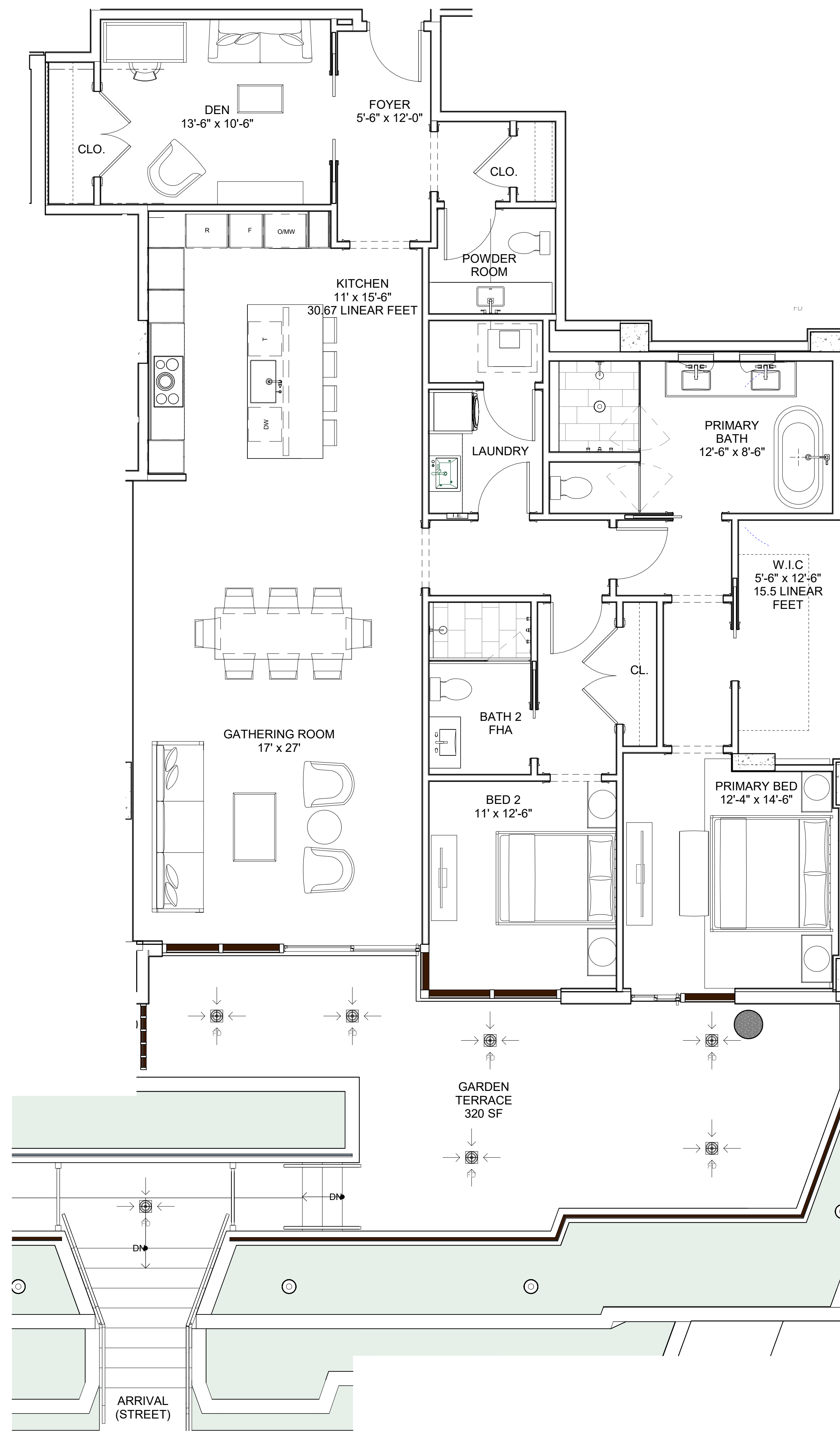

**ESTIMATED SELLABLE
OUTSIDE WALL : 2060 SF**

BOMA GROSS: (OUTSIDE FACE - EXTERIOR
WALL AND CORRIDOR, CENTERLINE - DEMISING
WALL, INSIDE WALL - SHAFTS)

NOTE: ALL AREAS ARE PRELIMINARY AND SUBJECT TO CHANGE.

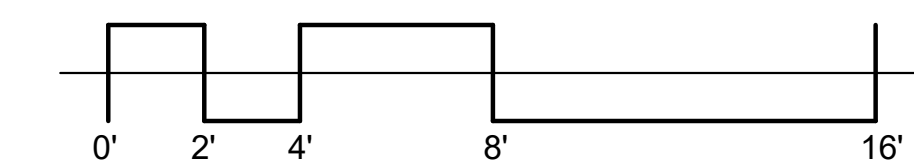

VILLA TYPE 1 (VILLA 9 MIRROR)
2 BR + DEN / 2.5 BATH

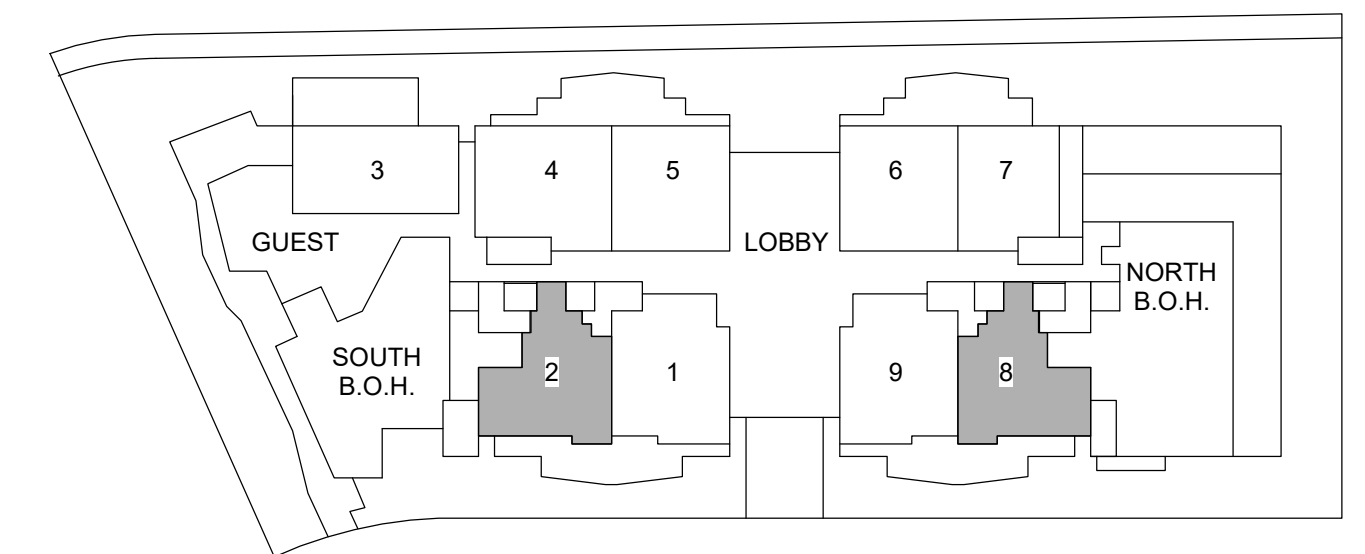
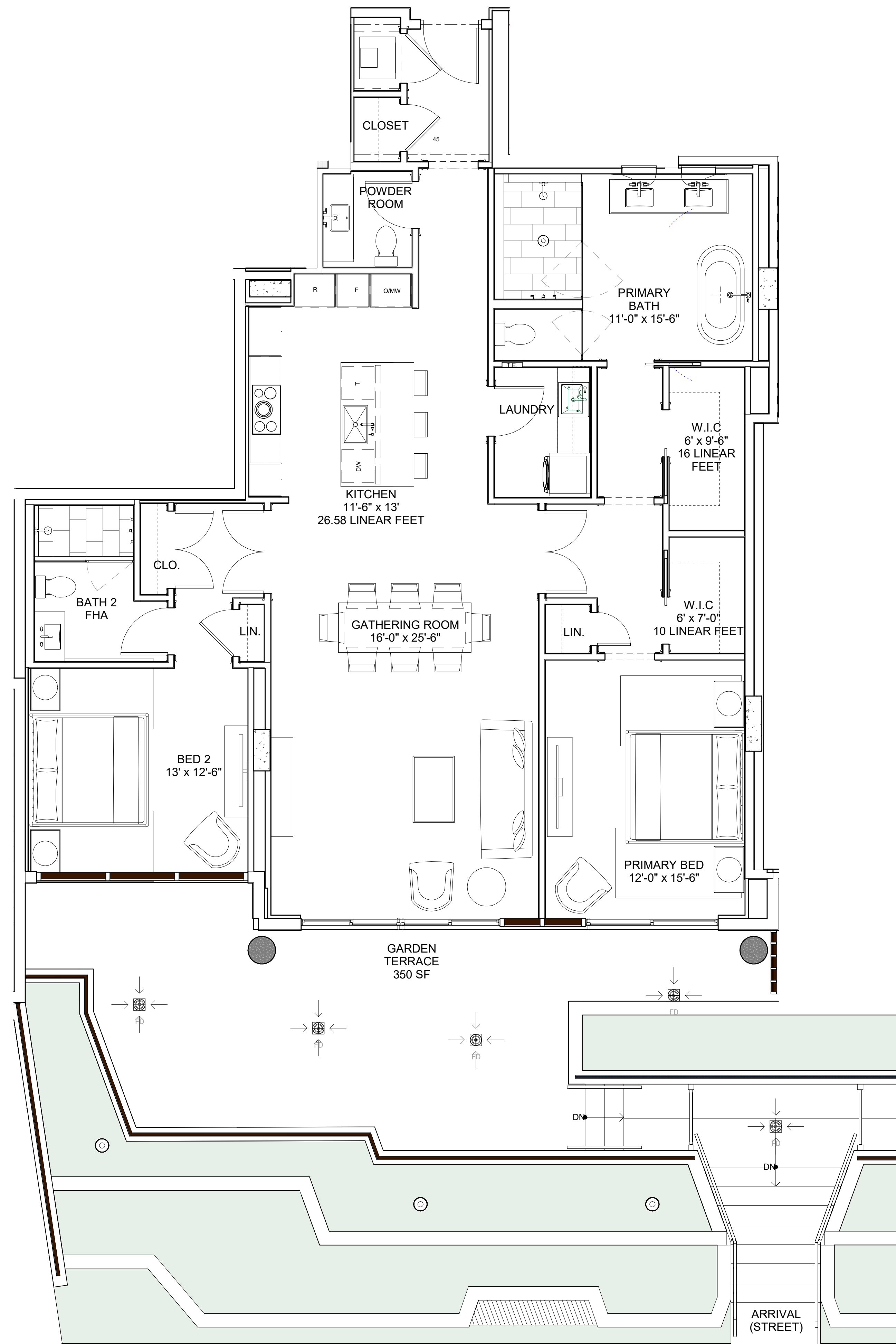

**ESTIMATED SELLABLE
OUTSIDE WALL : 1860 SF**

BOMA GROSS: (OUTSIDE FACE - EXTERIOR
WALL AND CORRIDOR, CENTERLINE - DEMISING
WALL, INSIDE WALL - SHAFTS)

NOTE: ALL AREAS ARE PRELIMINARY AND SUBJECT TO CHANGE.

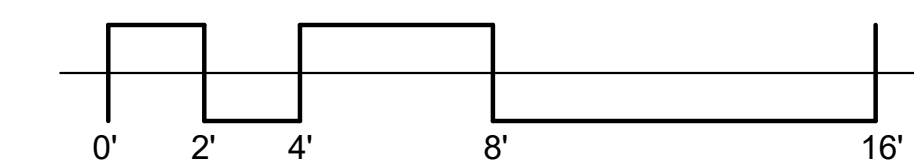

VILLA TYPE 2 (VILLA 8 MIRROR)

2 BR / 2.5 BATH

INTRACOASTAL

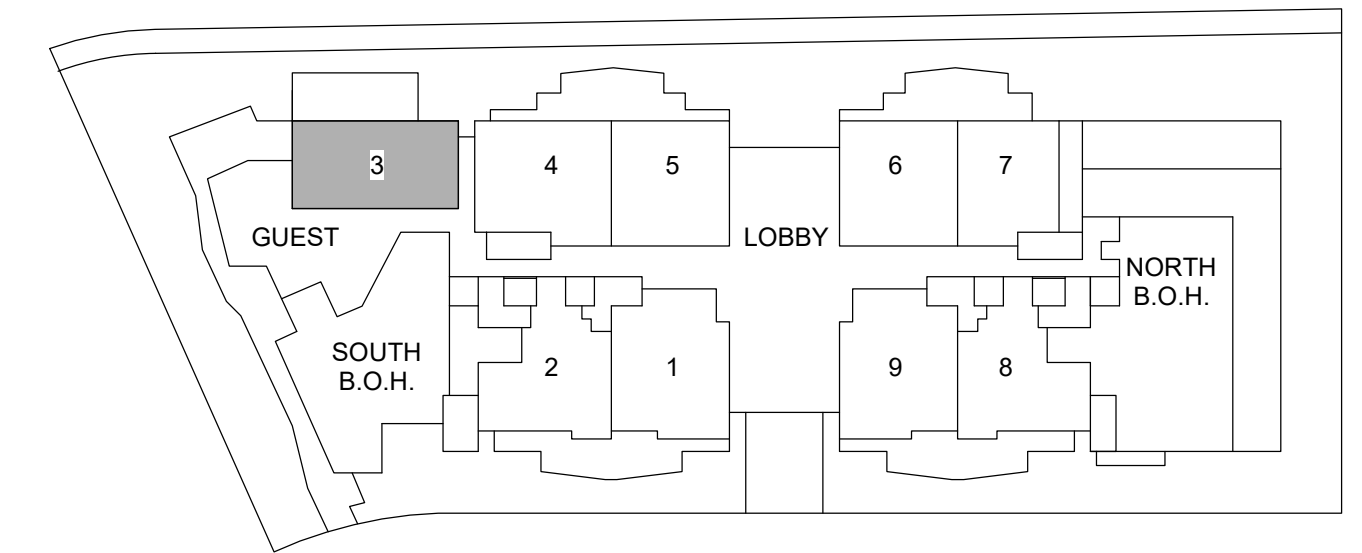
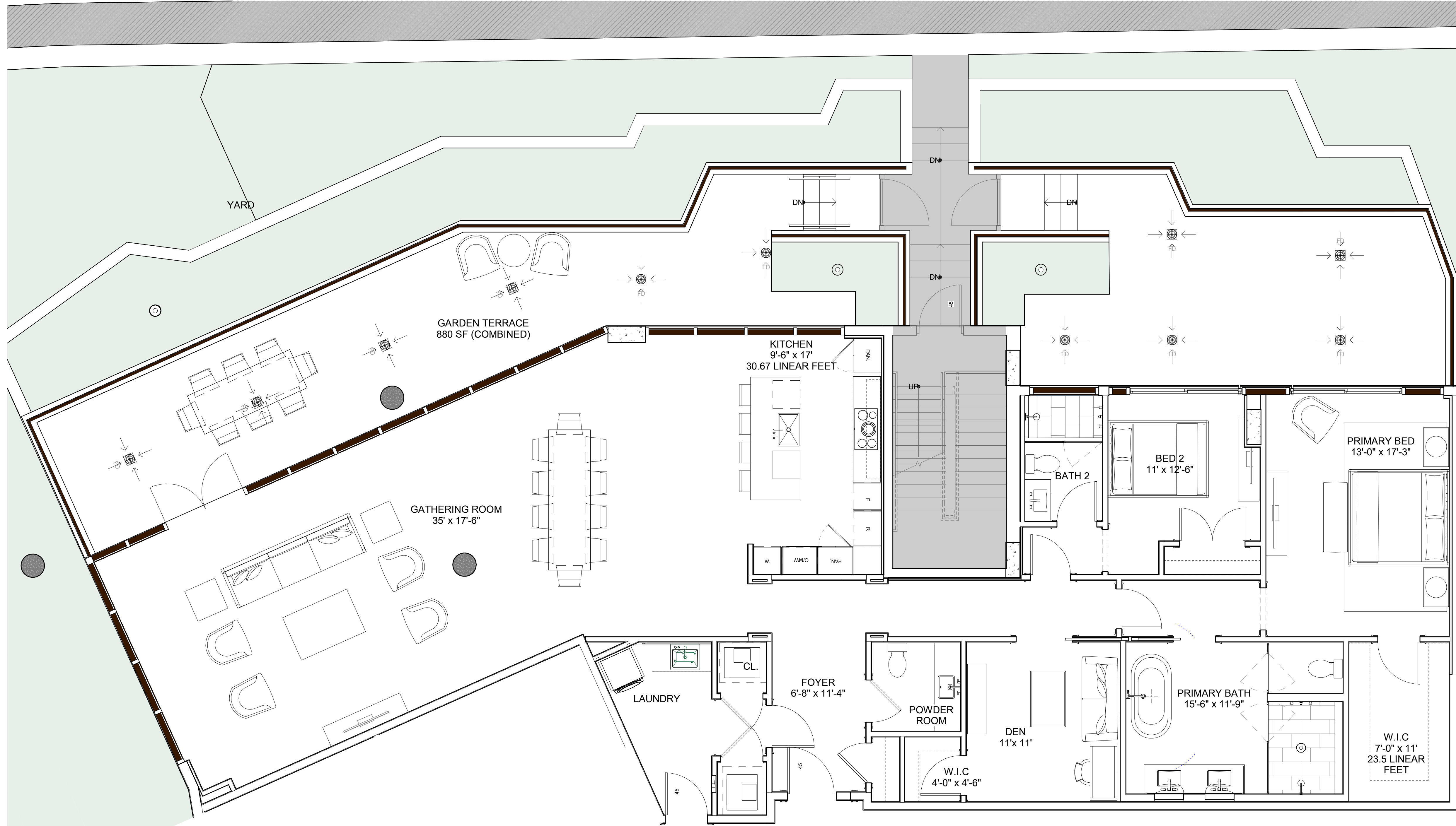

**ESTIMATED SELLABLE
OUTSIDE WALL : 2485 SF**

BOMA GROSS: (OUTSIDE FACE - EXTERIOR
WALL AND CORRIDOR, CENTERLINE - DEMISING
WALL, INSIDE WALL - SHAFTS)

NOTE: ALL AREAS ARE PRELIMINARY AND SUBJECT TO CHANGE.

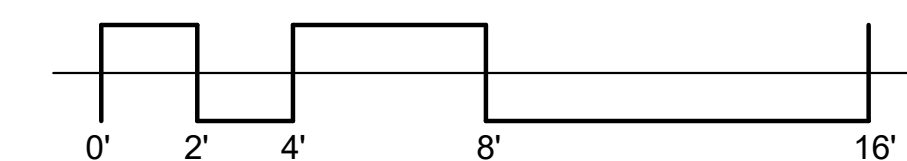

VILLA TYPE 3
2 BR + DEN / 2.5 BATH

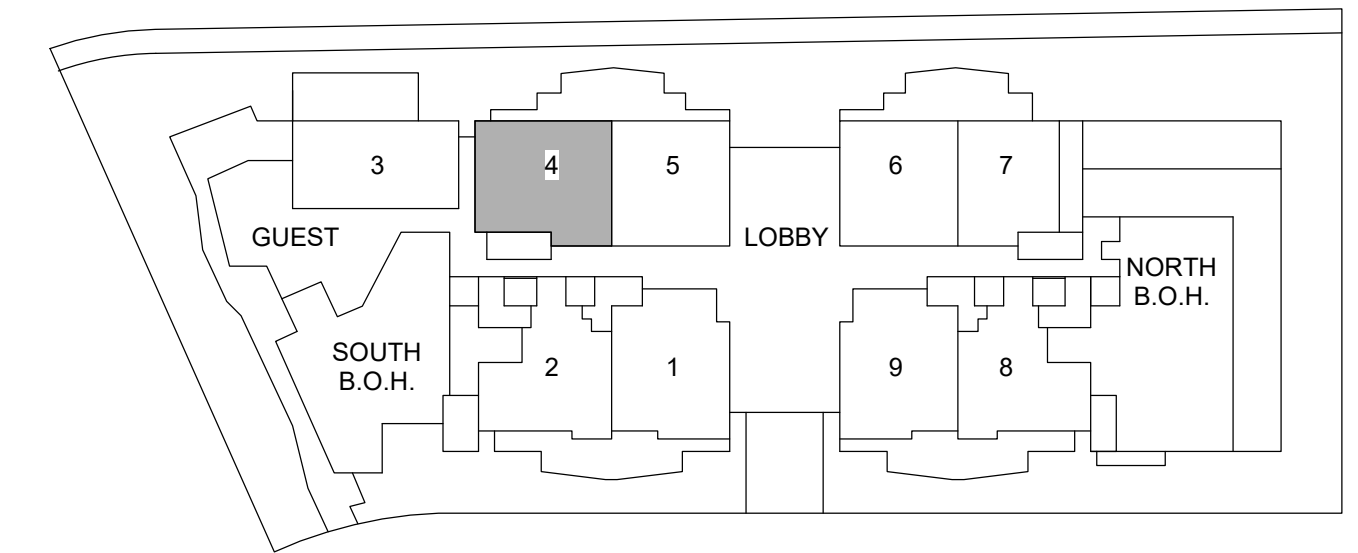
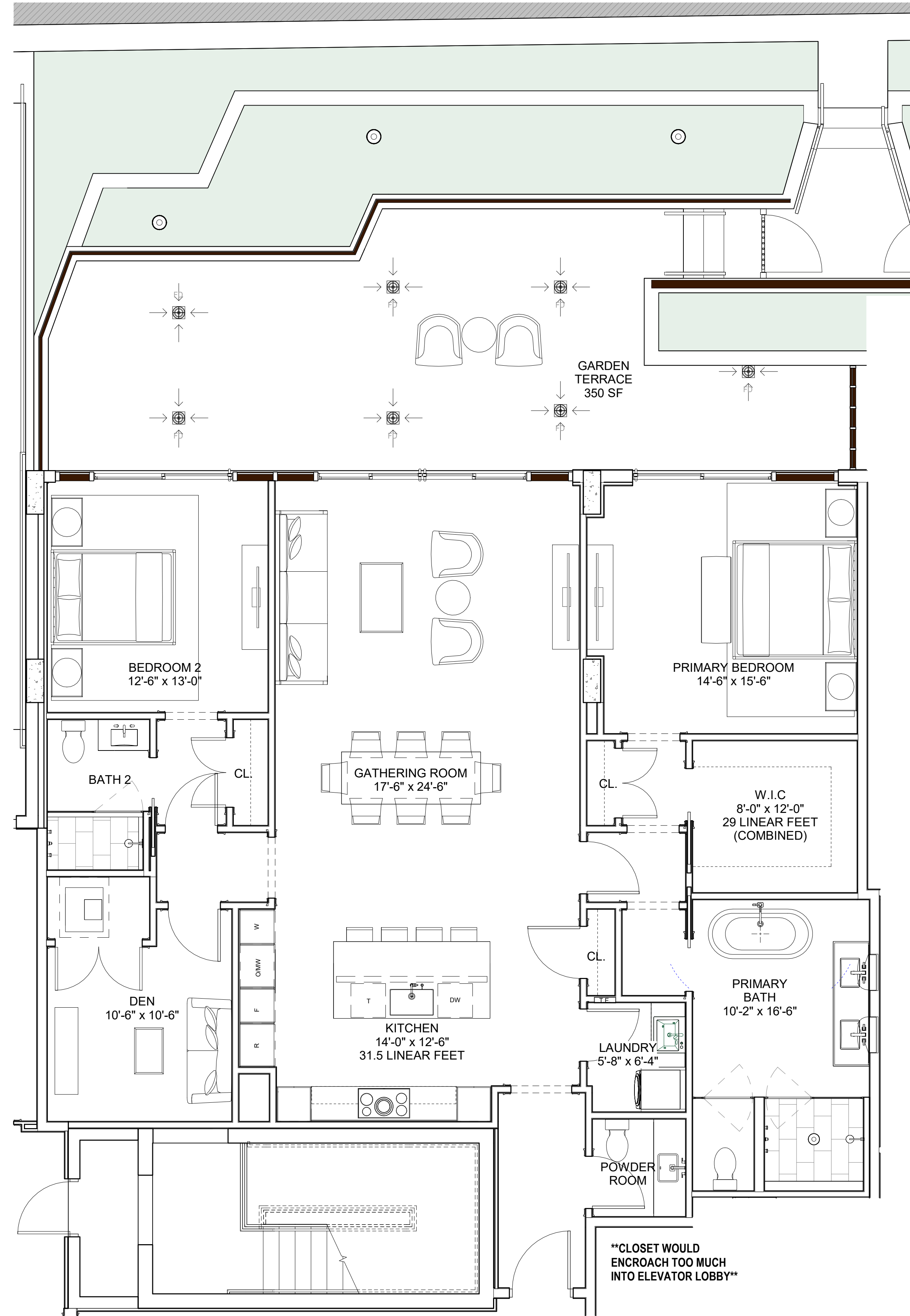

**ESTIMATED SELLABLE
OUTSIDE WALL : 1940 SF**

BOMA GROSS: (OUTSIDE FACE - EXTERIOR
WALL AND CORRIDOR, CENTERLINE - DEMISING
WALL, INSIDE WALL - SHAFTS)

NOTE: ALL AREAS ARE PRELIMINARY AND SUBJECT TO CHANGE.

VILLA TYPE 4

2 BR / 2.5 BATH

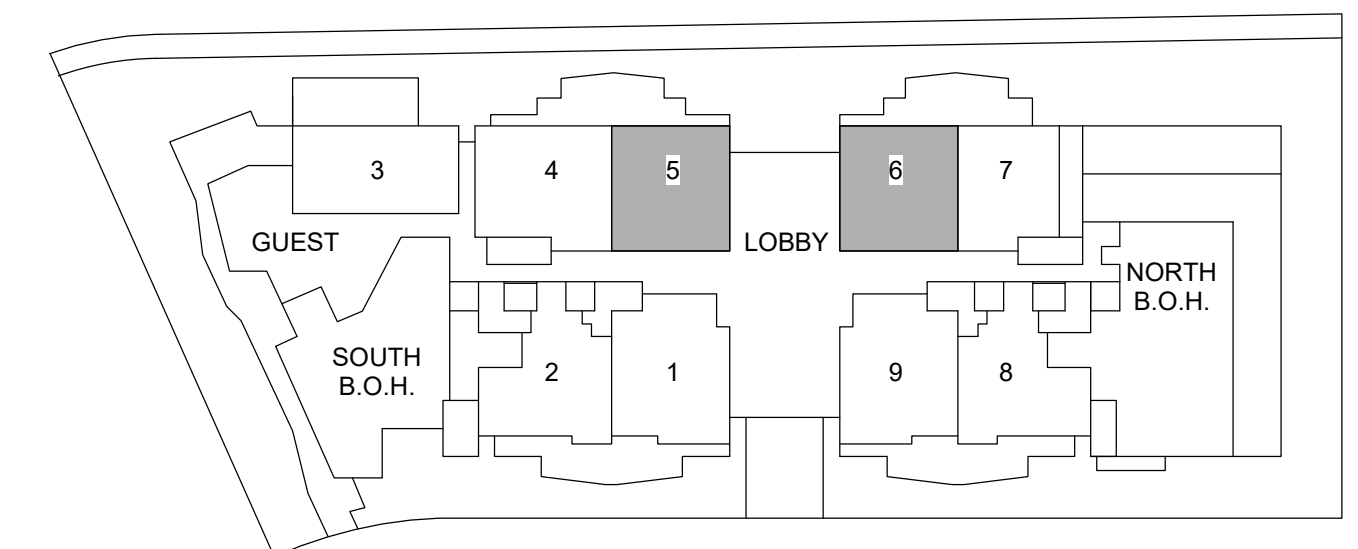
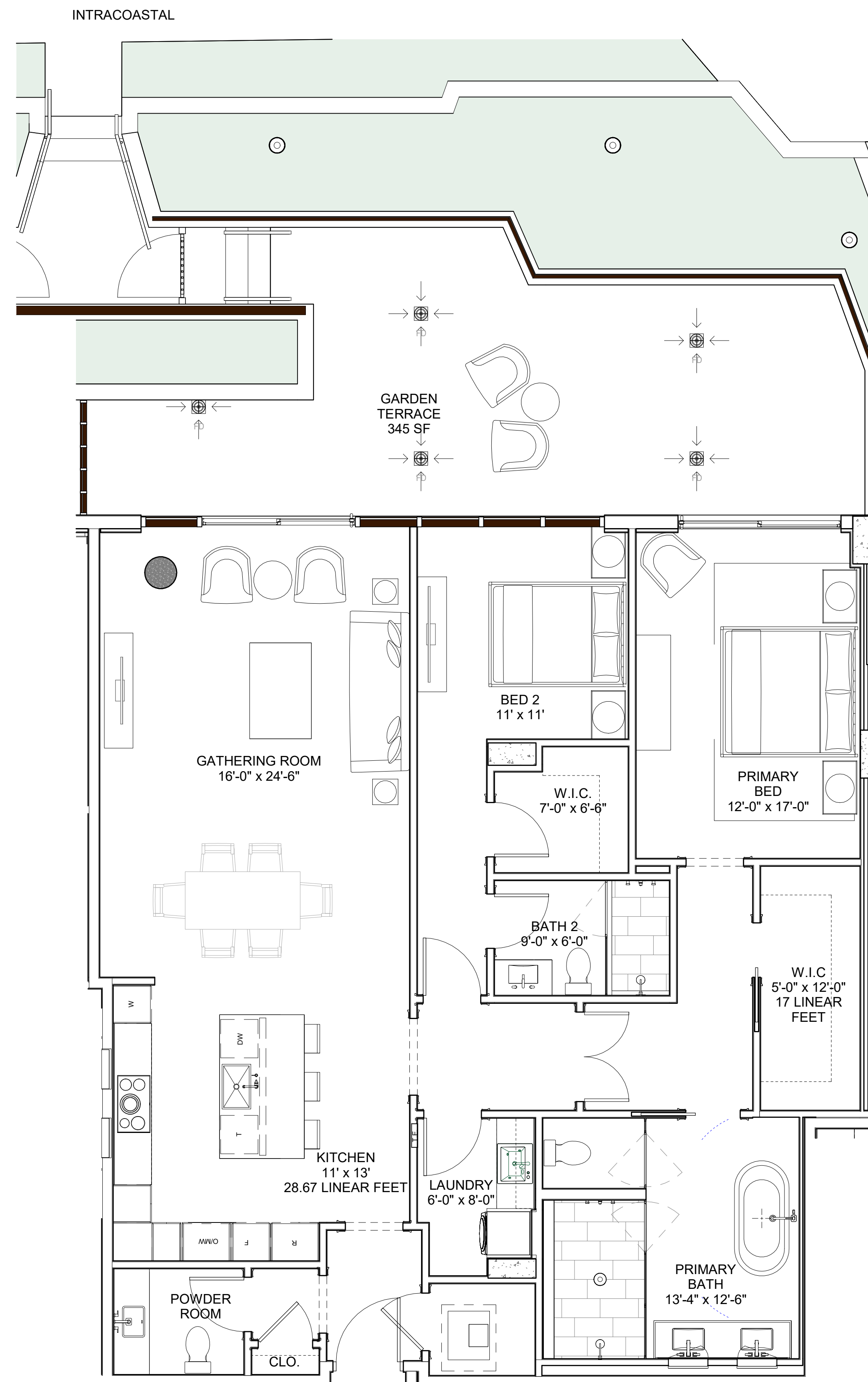

**ESTIMATED SELLABLE
OUTSIDE WALL : 1800 SF**

BOMA GROSS: (OUTSIDE FACE - EXTERIOR
WALL AND CORRIDOR, CENTERLINE - DEMISING
WALL, INSIDE WALL - SHAFTS)

NOTE: ALL AREAS ARE PRELIMINARY AND SUBJECT TO CHANGE.

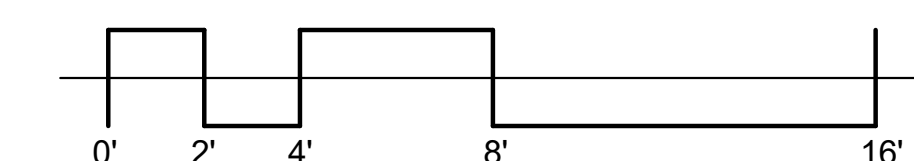

VILLA TYPE 5 (VILLA 6 MIRROR)

2 BR / 2.5 BATH

INTRACOASTAL

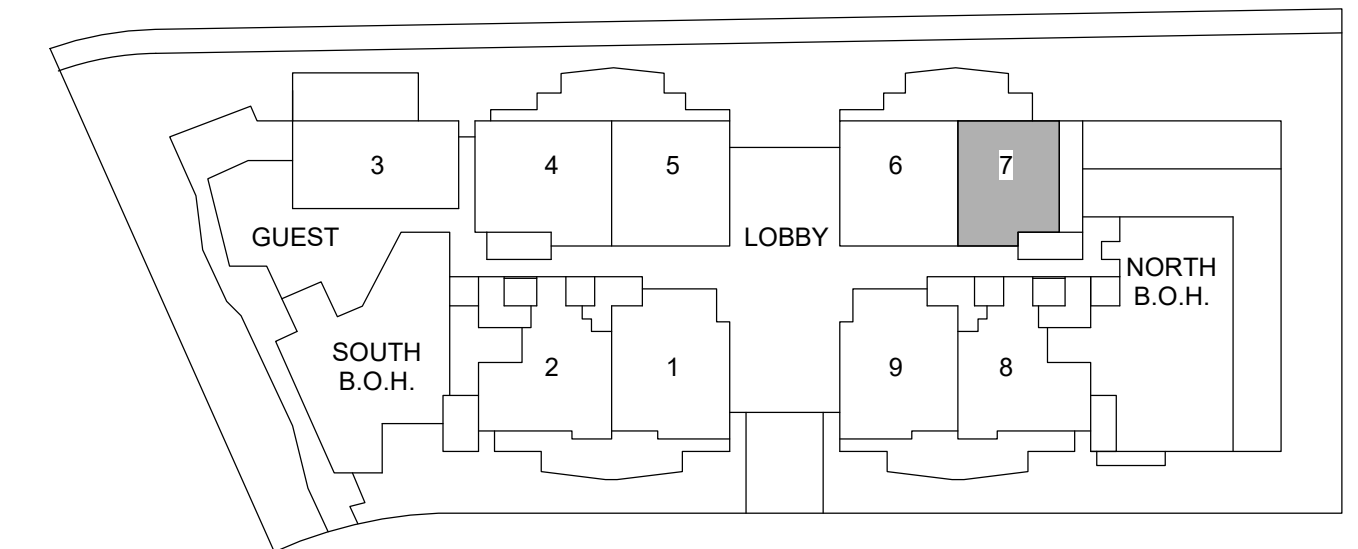
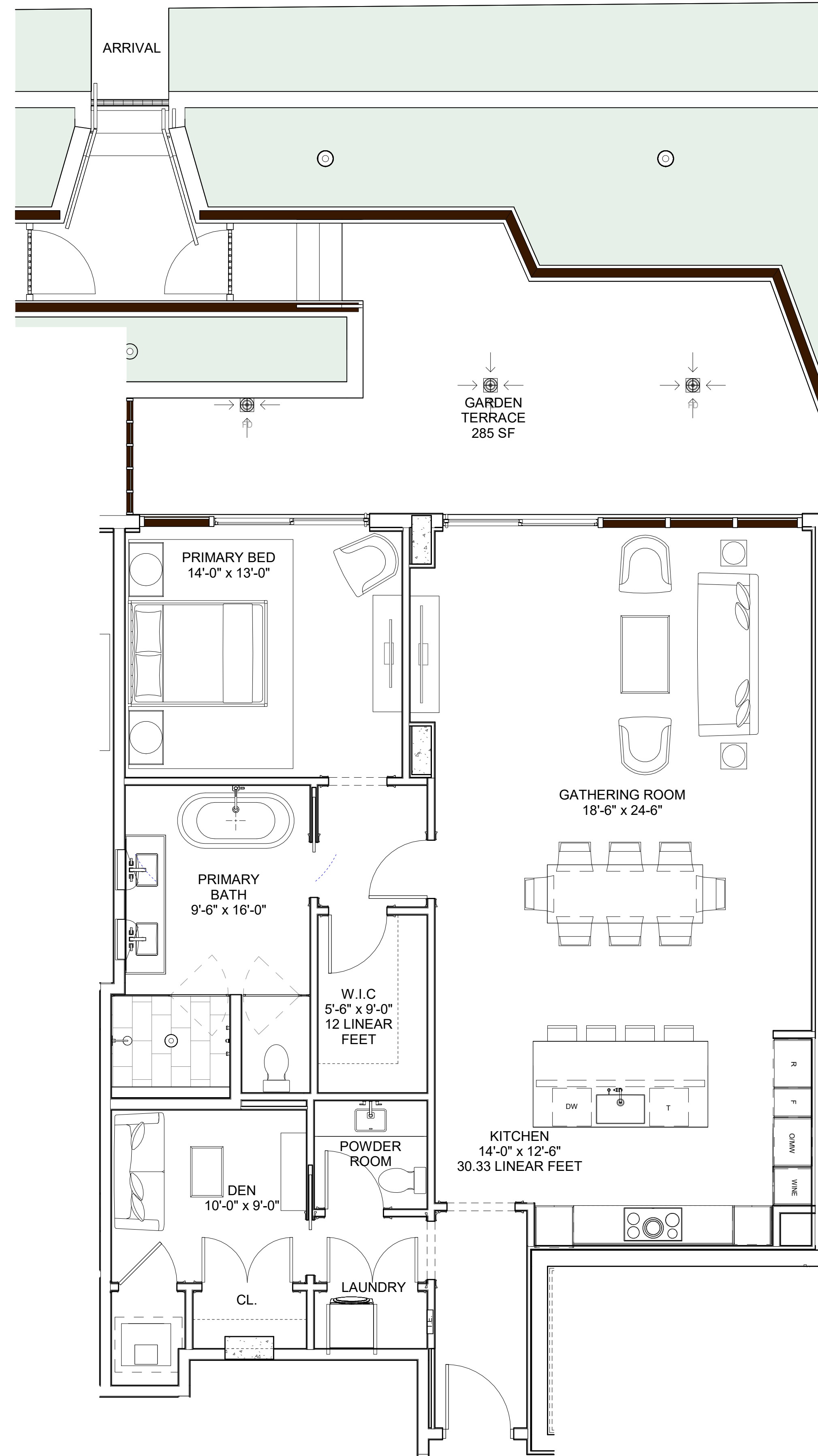

**ESTIMATED SELLABLE
OUTSIDE WALL : 1550 SF**

BOMA GROSS: (OUTSIDE FACE - EXTERIOR
WALL AND CORRIDOR, CENTERLINE - DEMISING
WALL, INSIDE WALL - SHAFTS)

NOTE: ALL AREAS ARE PRELIMINARY AND SUBJECT TO CHANGE.

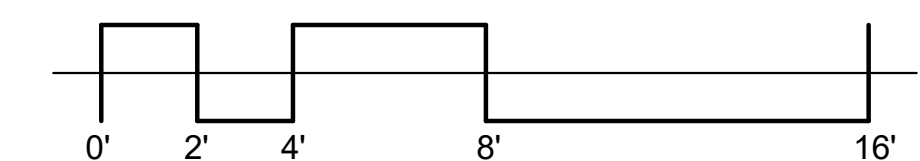

VILLA TYPE 7
1 BR + DEN / 1.5 BATH